



VANGO TECHNOLOGIES, INC.

V93XX_D1

Datasheet



Contents

Contents.....	2
List of Tables.....	8
List of Figure.....	12
Revision History.....	15
1. General Description.....	25
1.1 Functional Block Diagram	26
1.2 Pin Description.....	28
1.2.1 V9381 Pin Description	28
1.2.2 V9360 Pin Description	28
1.2.3 V9340 Pin Description	29
1.2.4 Pin Description	29
1.3 Parameters.....	31
1.4 Absolute Maximum Ratings.....	33
2 Registers.....	34
2.1 Registers List.....	34
2.2 Analog Control Registers	41
2.2.1 ANA_CTRL0 Register.....	41
2.2.2 ANA_CTRL1 Register.....	42
2.3 System Control & Status Register	44
2.3.1 SYS_BAUDCNT1 Register	44
2.3.2 SYS_BAUDCNT8 Register	44

2.3.3	SYS_INTSTS Register.....	44
2.3.4	SYS_INTEN Register	50
2.3.5	SYS_STS Register	53
2.3.6	SYS_MISC Register	56
2.3.7	SYS_BLKX Register	58
2.3.8	SYS_IOCFGXX Register	59
2.3.9	SYS_VERSION Register	62
2.4	Metering Control Registers.....	62
2.4.1	DSP_CTRL0 Register.....	62
2.4.2	DSP_CTRL1 Register.....	67
2.4.3	DSP_CTRL2 Register.....	70
2.4.4	DSP_CTRL3 Register.....	74
2.4.5	DSP_CTRL4 Register.....	78
2.4.6	DSP_CTRL5 Register.....	80
2.4.7	DSP_CTRL6 Register.....	83
2.4.8	DIP_SWELL_CTRL Register	87
2.5	Metering Data Register	88
2.5.1	DC Component Register.....	88
2.5.2	RMS Register	89
2.5.3	Active/ Reactive Power Register	90
2.5.4	Fundamental Wave Channel Register	91
2.5.5	Line Frequency Register.....	91
2.6	Energy Accumulator Register.....	92

2.7	Phase Measurement Register.....	95
2.8	Power-creep Threshold Register.....	96
2.9	Voltage Swell or Dip Threshold Register.....	96
2.10	Fast Detection Threshold Register.....	98
2.11	Waveform Data Register.....	98
2.12	Calibration Register.....	99
2.12.1	DC Bias Setting Register.....	99
2.12.2	RMS Calibration Register.....	99
2.12.3	Power Calibration Register.....	101
2.12.4	Threshold Register.....	102
2.12.5	Phase Calibration Register.....	105
2.12.6	Bandpass Filter Register.....	105
2.13	Checksum Register.....	106
3	Main Power Supply.....	110
3.1	Power Supply Monitoring Circuit.....	110
3.2	Digital Power Supply.....	111
4	Bandgap circuit.....	112
5	Clock.....	114
5.1	External input high-frequency clock.....	116
5.2	High-Frequency RC Oscillator.....	116
5.3	Low-Frequency RC Oscillator.....	117
5.4	External Input Clock.....	117
6	RESET.....	118

6.1	Reset Related Registers	118
6.2	External Reset	118
6.3	RX Reset	119
6.4	Global Software Reset	120
7	UART	122
7.1	Overview	122
7.2	Communication Protocol	123
7.3	Broadcast Communication	124
7.4	Read Operation	126
7.5	Write Operation.....	127
7.6	Block Reading Operation	129
8	SPI.....	132
8.1	Overview	132
8.2	Write Operation.....	133
8.3	Read Operation	134
8.4	Initialize interface	135
8.5	4-wire SPI Mode	135
8.6	3-wire SPI Mode	135
9	DSP	137
9.1	Overview	137
9.2	Features	137
9.3	Functional Diagram.....	137
9.4	Analog Inputs.....	140

9.5	Analog-to-Digital Conversion.....	142
9.6	Phase Compensation.....	143
9.7	Generation of raw waveform data.....	144
9.8	RMS Calculation and Calibration.....	145
9.9	Active Power Calculation and Calibration	146
9.10	Reactive Power and Calibration	146
9.11	Apparent Power Calculation	147
9.12	Apparent Power Calculation	149
9.13	Power-creep Detection.....	149
9.14	Frequency measurement	150
9.15	Phase measurement.....	153
9.16	Calibration	154
10	Active Waveform upload and buffer	155
10.1	Active Waveform upload	155
10.1.1	Overview	155
10.1.2	Timing and Format.....	156
10.2	Waveform Buffer	157
11	Electrical Signal monitoring	158
11.1	158
11.2	Zero-crossing Detection	158
11.3	Voltage Swell/Dip.....	159
11.4	Over-voltage and under-voltage/Over-current and under-current.....	160
12	Energy Accumulator	162

12.1	High-speed Energy Accumulator	163
12.2	Low-speed Energy Accumulator	163
12.3	CF Output.....	164
12.4	Energy Accumulator Power-creep Detection.....	164
12.5	Active Accumulation uploading Interface	165
13	Signal IO Ports.....	166
13.1	Overview	166
13.2	Functional Description.....	166
14	Roche coil processing	168
15	Packaging Information.....	169
16	Reflow soldering process	172
17	Outline Dimensions	173

List of Tables

Table1.	Document Version History.....	15
Table2.	Pin description	29
Table3.	Parameters.....	31
Table4.	Absolute maximum ratings.....	33
Table5.	Register list.....	34
Table6.	Analog Control Register 0 (0x00, ANA_CTRL0).....	41
Table7.	Analog Control Register 1 (0x01, ANA_CTRL1).....	42
Table8.	UART transmitting data 1bit count value (0x70, SYS_BAUDCNT1)	44
Table9.	UART receiving data 8bit count value (0x71, SYS_BAUDCNT8)	44
Table10.	System Interrupt Register (0x72, SYS_INTSTS).....	44
Table11.	System Interrupt Enable Register (0x73, SYS_INTEN).....	50
Table12.	System Status Register (0x74, SYS_STS)	53
Table13.	System Control Register (0x75, SYS_MISC).....	56
Table14.	Block-reading Address Register 0 (0x79, SYS_BLK0_ADDR)	58
Table15.	Block-reading Address Register 1 (0x7A, SYS_BLK1_ADDR)	58
Table16.	Block-reading Address Register 2 (0x7B, SYS_BLK2_ADDR)	59
Table17.	Block-reading Address Register 3 (0x7C, SYS_BLK3_ADDR).....	59
Table18.	IO Configuration Register 0 (0x7D, SYS_IOCFIGX0)	59
Table19.	P0CFG Bit[5:0] Description	60
Table20.	IO Configuration Register 1 (0x7E, SYS_IOCFIGX1).....	62
Table21.	Version Information Register (0x7F, SYS_VERSION).....	62

Table22.	Metering Control Register 0 (0x02, DSP_CTRL0).....	62
Table23.	Metering Control Register 2 (0x03, DSP_CTRL1).....	67
Table24.	Metering Control Register 2 (0x04, DSP_CTRL2).....	70
Table25.	Metering Control Register 3 (0x05, DSP_CTRL3).....	74
Table26.	Metering Control Register 4 (0x06, DSP_CTRL4).....	78
Table27.	Metering Control Register 5 (0x07, DSP_CTRL5).....	80
Table28.	Metering Control Registers (0x80, DSP_CTRL6).....	83
Table29.	Voltage surge control register (0x8f, DIP_SWELL_CTRL).....	87
Table30.	DC Component Register	88
Table31.	Voltage/ Current/ Measurement Signal (M) RMS Register	89
Table32.	Active/ Reactive Power Register	90
Table33.	Fundamental Wave Channel Instantaneous Register	91
Table34.	Fundamental Wave Channel Average Register	91
Table35.	Line Frequency Register (0x21, DSP_DAT_FRQ)	91
Table36.	Energy Accumulator Register	92
Table37.	Phase Measurement Register	95
Table38.	Power-creep Threshold Register	96
Table39.	Voltage Swell or Dip Threshold Register.....	96
Table40.	Fast detection Threshold Register	98
Table41.	Waveform Data Register	98
Table42.	DC Bias Setting Register	99
Table43.	Voltage/ Current/ Measurement RMS Calibration Register.....	99
Table44.	Total-wave Active/ Reactive Power Calibration Register	101

Table45.	Threshold Register.....	102
Table46.	Phase Calibration Register (0x33, DSP_CFG_PHC)	105
Table47.	Bandpass Filter Register (0x37, DSP_CFG_BPF)	105
Table48.	Checksum Register (0x38, DSP_CFG_CKSUM).....	106
Table49.	Self-checking Register	106
Table50.	Register for Bandgap Circuit	112
Table51.	Clock Generation Related Registers	114
Table52.	Reset Related Registers	118
Table53.	UART communication errors	122
Table54.	UART Communication Timing Parameters	123
Table55.	Structure of Data Byte (B7:B0) From Master MCU to V93XX on Broadcast Operation	124
Table56.	Structure of Data Byte (B7:B0) From Master MCU to V93XX on Read Operation.....	126
Table57.	Structure of Data Byte (B7:B0) From V93XX to Master MCU on read Operation.....	126
Table58.	Structure of Data Byte (B7:B0) From Master MCU to V93XX on Write Operation.....	127
Table59.	Structure of Data Byte (B7:B0) From V93XX to Master MCU on Write Operation.....	128
Table60.	Structure of Data Byte (B7:B0) From Master MCU to V93XX on block reading Operation	130
Table61.	Structure of Data Byte (B7:B0) From V93XX to Master MCU on block reading Operation	131
Table62.	SPI communication errors.....	132
Table63.	Structure of Data Byte (B7:B0) From Master MCU to V93XX on write Operation.....	133
Table64.	Structure of Data Byte (B7:B0) From Master MCU to V93XX on read Operation	134
Table65.	Structure of Data Byte (B7:B0) From V93XX to Master MCU on read Operation.....	134
Table66.	SPI interface initialization data (hexadecimal).....	135
Table67.	Analog PGA Gain Configuration for Current and Voltage Analog Input	142

Table68.	Enable/Disable ADCs.....	142
Table69.	f_{smp} Determines Phase Compensation Resolution and Correction Range	143
Table70.	Registers for Phase Compensation	144
Table71.	Enable/Disable Digital Inputs	145
Table72.	DPGA Gain Selection for Digital Signals.....	145
Table73.	Reactive power Selection.....	147
Table74.	Power-creep Detection Description	149
Table75.	Power-creep Threshold Register.....	150
Table76.	Frequency measurement configure register	151
Table77.	Frequency register source FRQ_SEL and DSP_CTRL6 Relationship description	153
Table78.	Frequency Constant Description	153
Table79.	Frequency Constant Description	154
Table80.	Active waveform data upload configuration	155
Table81.	Active waveform data upload format	156
Table82.	waveform buffer data format.....	157
Table83.	Reflow profile conditions	172

List of Figure

Figure1.	Functional block diagram	26
Figure2.	V9381 Pin Description.....	28
Figure3.	V9360 Pin Description.....	28
Figure4.	V9340 Pin Description.....	29
Figure5.	Main Power System	110
Figure6.	Power-down monitoring	110
Figure7.	Clock generation	114
Figure8.	Timing for RSTN	118
Figure9.	Timing for RX Reset of UART.....	119
Figure10.	Timing for RX Reset of SPI	120
Figure11.	Timing of Global Software Reset.....	121
Figure12.	Structure of an 11-Bit data byte (from LSB to MSB).....	122
Figure13.	Timing of UART Communication	123
Figure14.	command frame for broadcast writing operation	124
Figure15.	Communication protocol for read operation	126
Figure16.	Communication protocol for write operation.....	127
Figure17.	address mapping for block reading.....	129
Figure18.	Communication protocol for block reading operation	130
Figure19.	Communication protocol for SPI write operation	133
Figure20.	Communication protocol for SPI read operation.....	134
Figure21.	Communication protocol for 4 wire SPI mode	135

Figure22.	Communication protocol for 3 wire SPI mode	136
Figure23.	Functional Diagram 1 of Metering DSP	137
Figure24.	Functional Diagram 2 of Metering DSP	139
Figure25.	CT for Current Analog Input	140
Figure26.	Shunt Resistor Network for Current Analog Input.....	140
Figure27.	Analog Input of Voltage	141
Figure28.	Current/voltage channel analog gain configuration	141
Figure29.	Phase Compensation Schematics.....	143
Figure30.	Generation of raw waveform data.....	144
Figure31.	RMS Calculation and Calibration.....	146
Figure32.	Signal Processing for Active Power Calculation and Calibration.....	146
Figure33.	Signal Processing for Reactive Power Calculation and Calibration	146
Figure34.	Apparent Power Calculation	147
Figure35.	Frequency measurement	150
Figure36.	Communication timing of DMA SPI.....	156
Figure37.	output waveform for voltage/current zero-crossing	158
Figure38.	Over-voltage and under-voltage/Over-current and under-current detect.....	160
Figure39.	Functional block diagram of energy bucket.....	162
Figure40.	Functional Block Diagram of signal IO ports	166
Figure41.	Taping Information of V9340	

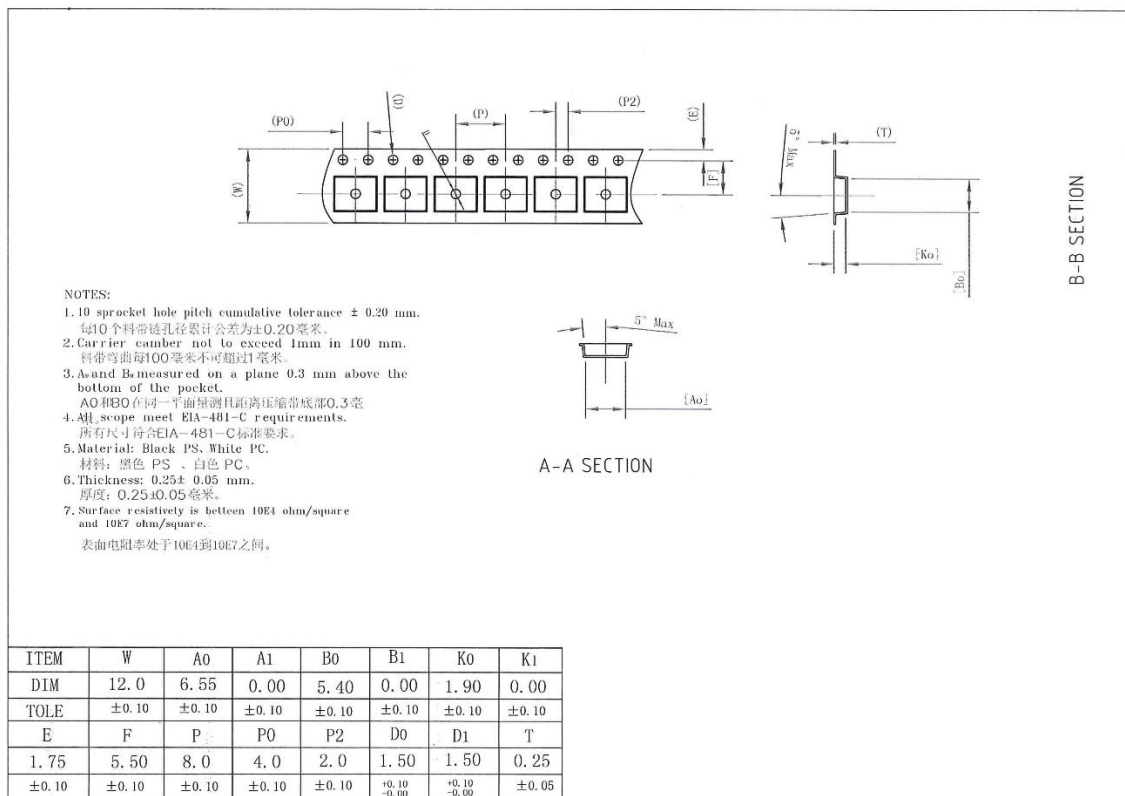

..... 169

Figure42. Taping Information of V9360 170

Figure43. Taping Information of V9381 171

Figure44. A typical lead-free reflow mode 172

Figure45. Outline dimension for V9381 173

Figure46. Outline dimension for V9360 173

Figure47. Outline dimension for V9340 174

Revision History

Table1. Document Version History

Date	Version	Description
2019.07.19	2.0	Initial release
2020.11.25	2.1	Modify the description of SYS_STS register.
2020.02.18	3.1	<p>Modify ANA_CTRL0 BIT13 and BIT14 function</p> <p>Modify ANA_CTRL1 BIT7 and BIT23 function</p> <p>Add pull-up resistance to TX, RX and RSTN pin</p> <p>When the RSTN pin remains low for a certain period of time, the chip will be reset. The time was changed from 1 ms to 2 ms</p> <p>Open the input short circuit function of voltage channel and current channel</p> <p>On-chip reference voltage changed to 1.21 V</p> <p>The power supply voltage range is changed to 2.6 ~ 3.6 V</p> <p>The power down threshold voltage is changed to 2.6 ~ 3.1 V</p>
2022.01.20	3.2	Delete relevant contents of Roche coil
2022.03.01	3.3	<p>Modify SYS_INTSTS and SYS_INTEN registers, increase the overflow interrupt of high-speed energy accumulator</p> <p>Modify the description of DMA_MODE bit in DSP_CTRL5 register (added description: at least one channel of waveform buffer and upload must be opened before enabling DMA transmission).</p> <p>Modify the description of bit3 and bit4 in DSP_CTRL5 registers, description of DMA channel manual switch for waveform upload.</p> <p>Delete the frequency function in DSP_CTRL0 register.</p> <p>Modify the function description of UPERIOD and IPERIOD from half cycle unit to cycle unit</p> <p>Modify SHORT_I of ANA_CTRL0, Change to current IA channel</p>

		<p>ADC input short circuit</p> <p>Modify the description of RCL clock intervals as determined time, and the algorithm is the longest time interval x 1.5</p> <p>Modify the description of forced shutdown energy accumulator and CF output function in SYS_MISC register</p> <p>The power down threshold voltage is changed to 2.6 ~ 3.05 V</p>
2022.03.25	3.4	Modify the description of CLK1 in Chapter 5
2022.05.19	3.5	<p>Add Energy accumulator counter description</p> <p>Delete temperature measurement function</p> <p>ADD V9340/V9343 type</p>
2022.08.13	3.6	<p>Modify the table of parameter</p> <p>Modify UART baud rate range</p> <p>Table 5-1 in the field register, ANA_CTRL1 instead of DSP_CTRL1.</p>
2022.10.11	3.7	Modify the description of voltage dip in Section 11.2
2023.03.01	3.8	Change V9343 to V9340T
2023.05.08	3.9	<p>Modify the RCHTRIM description of the ANA_CTRL1 register;</p> <p>Modify the description of P0CFG Bit5~Bit0;</p>
2023.08.18	V4.0	Modify according to D1 version chip;
2023.11.28	V4.1	<p>Modify RCH bit width description;</p> <p>Add V9340B</p>
2023.12.29	V4.2	<p>Add description to the UART chapter;</p> <p>Add description to the DSP chapter;</p> <p>Add a section about the sample meter calibration method;</p>
2024.03.29	V4.3	Delete V9340T, V9340B;
2024.05.20	V4.4	<p>Modify the typical values of RCL;</p> <p>Modify the RX reset timing chart during SPI communication;</p> <p>Modify the RX reset timing diagram during UART communication;</p>
2024.07.09	V4.5	Correction of working temperature to -40~105 °C
2024.07.29	V 4.6	Modify descriptive errors

2024.10.28	V4.7	Add packaging information and reflow soldering information; Modify electrical characteristic parameters.
2025.01.22	V4.8	Delete the POR (Power-On Reset) function.
2025.07.15	V4.9	Add the taping information for each model.
2025.09.17	V4.10	Add the refresh time and stabilization time for both instantaneous values and average values to the Performance Parameters section.

1. General Description

The V93XX is a single-phase metering chip which supports the total-wave and fundamental-wave of various modes and supports various power grids to monitor events. Furthermore, the waveform data can be transmitted via DMA by SPI protocol, or storage locally through the waveform buffer.

- Main Power: 3.3 V power supply, voltage input range 2.6 V to 3.6 V.
- Reference voltage: 1.21 (typical T.C. 10 ppm/°C)
- Low-power design: the typical consumption in normal operation is about 2.6 mA.
- Metering Features:
 - 3 independent oversampling Σ/Δ ADCs: one of the ADC (channel A) can measure voltage, the other ADC with multifunction measure current.
 - Highly Metering Accurate:

Supports the requirements of IEC 62053-21:2020/ IEC 62053-22:2020 and IEC 62053-23:2020.

Less than 0.1% error in active energy metering over a dynamic range of 5000:1

Less than 0.2% error in reactive energy metering over a dynamic range of 5000:1

Less than 0.5% error in current/voltage RMS over a dynamic range of 5000:1.

- Supports various measurements:

DC components of voltage and current signal

Total /fundamental instantaneous/average current/voltage RMS

Total instantaneous/average active /reactive/apparent power

10 or 12 cycles of total RMS

Fundamental instantaneous/average active /reactive/apparent power

active/reactive energy, active/reactive/apparent power, Irms, constant value, and fundamental wave are selectable

Line frequency and phase

- DC signals measurement
- Software calibration
- Accelerating calibration when weak current is applied.
- Supports detection for over-current, over-voltage, under-current, under-voltage, voltage dip, and voltage swell
- Supports waveform buffer and waveform transmitted by DMA
- Supports active upload for energy accumulation

- Current input: current shunt resistor, CT, Hall cell, TMR and Roche coil supportive
- CTI input clock frequency: 6.5536 MHz
- Supports UART communication interface
- Supports SPI communication interface
- Operating Temperature:
- -40 ~ +105 °C
- Storage Temperature: -55~+150 °C
- Package: SSOP24, SOP16, SOP8

1.1 Functional Block Diagram

Figure1. Functional block diagram

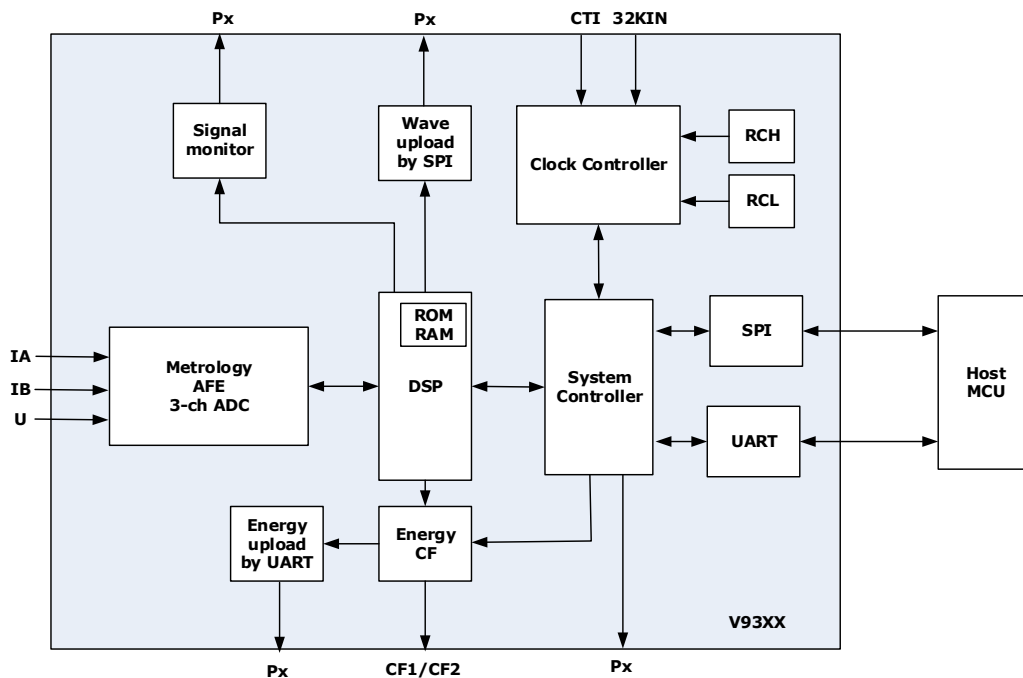

1.2 Pin Description

1.2.1 V9381 Pin Description

Figure2. V9381 Pin Description

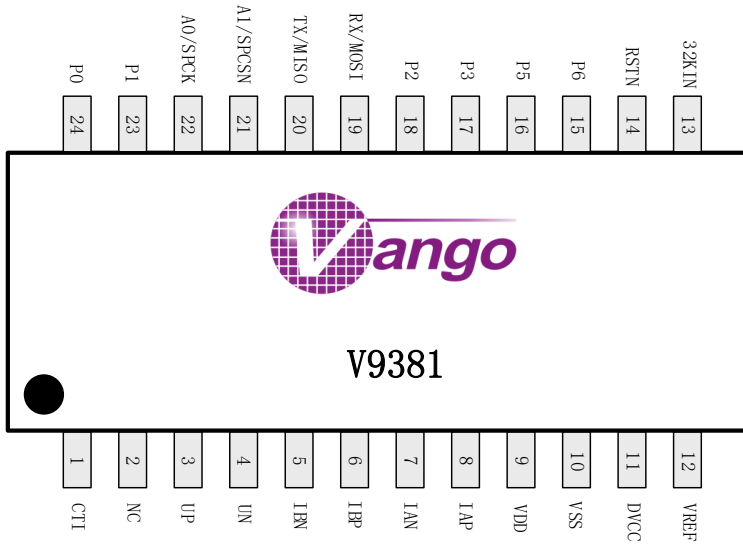

1.2.2 V9360 Pin Description

Figure3. V9360 Pin Description

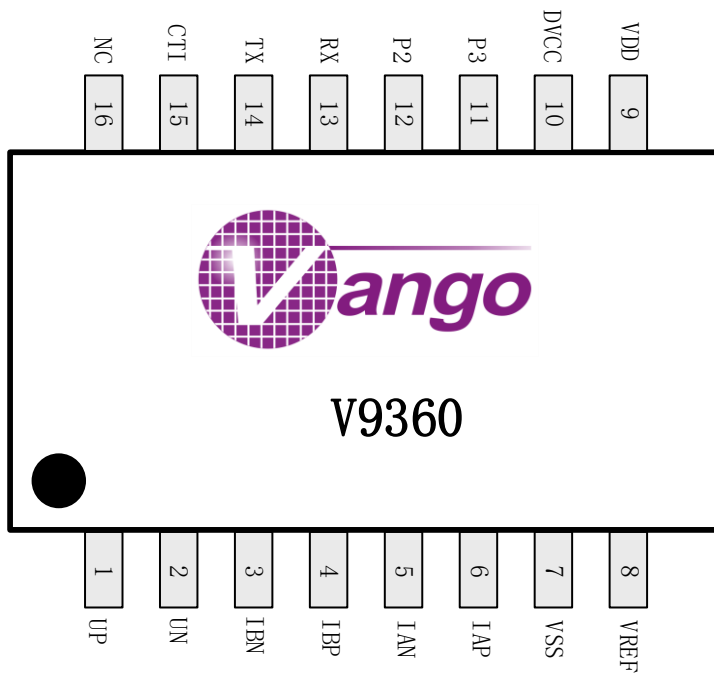

1.2.3 V9340 Pin Description

Figure4. V9340 Pin Description

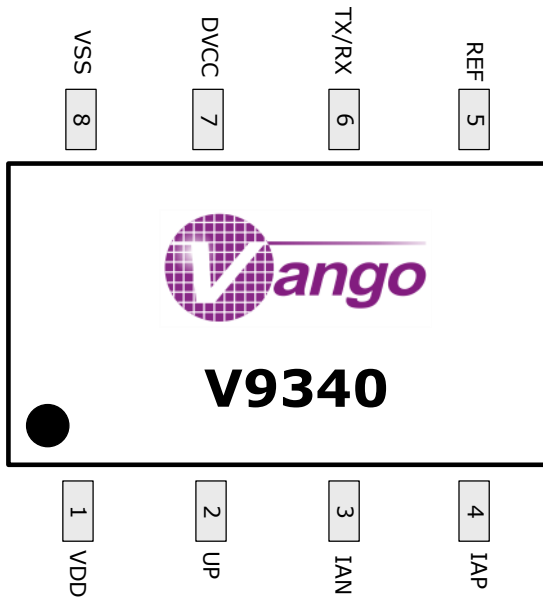

1.2.4 Pin Description

Table2. Pin description

Pin No.			Mnemonic	Type	Description
V9381	V9360	V9340			
1	15		CTI	Input	Input pin for 6.5536 MHz clock.
2	16		NC		Floating
3	1	2	UP	Input	Positive input pin for Voltage Channel Sampling.
4	2		UN	Input	Negative input pin for Voltage Channel Sampling.
5	3		IBN	Input	Negative input pin for current channel B sampling.
6	4		IBP	Input	Positive input pin for current channel B sampling.
7	5	3	IAN	Input	Negative input pin for current channel A sampling.
8	6	4	IAP	Input	Positive input pin for current channel A sampling.
9	9	1	VDD	Power	3.3 V power supply. This pin must be decoupled to a ≥ 0.1

					μ F capacitor.
10	7	8	VSS	Ground	Ground
11	10	7	DVCC	Power	Digital power output. This pin must be decoupled to a 0.1 μ F capacitor.
12	8	5	VREF	Input/ Output	On-chip reference voltage. This pin must be connected to a 1 μ F capacitor, and then grounded.
13	-		X32KIN	Input	32 KHz CLK input pin (Digital IO interface).
14	-		RSTN	Input	Reset input, active low. After power on, the "RSTN" could be driven low for at least 2 ms by MCU to force the chip into the reset state. There is a pull-up resistor inside the chip, which is about 50K ohm.
15	-		P6	Output	CF1/ CF2/ single interruption/ all interruption/ automatic data uploads
16	-		P5	Output	CF1/ CF2/ single interruption/ all interruption/ automatic data uploads
17	11		P3	Output	CF1/ CF2/ single interruption/ all interruption/ automatic data uploads
18	12		P2	Output	CF1/ CF2/ single interruption/ all interruption/ automatic data uploads
19	13	6	RX/MOSI	Input	UART communicates with RX pin. / SPI interface in slave mode. It's used for data input. There is a pull-up resistor inside the chip, which is about 50 Kohm.
20	14	6	TX/MISO	Output	UART communicates with TX pin. / SPI interface in slave mode. It's used for data output. There is a pull-up resistor inside the chip, which is about 50 Kohm.
21	-		A1/SPCSN	Input	Address select pin 1 for UART. / Chip select pin for SPI
22	-		A0/SPCK	Input	Address select pin 0 for UART. / SPI interface in slave mode. It's used for clock input.

23	-		P1	Output	CF1/ CF2/ single interruption/ all interruption/ automatic data uploads
24	-		P0	Output	CF1/ CF2/ single interruption/ all interruption/ automatic data uploads

1.3 Parameters

Table3. Parameters

Unless otherwise specified, the data are based on the test results of TA = 25 °C, VDD = 3.3 V.

Parameter	Min.	Typ.	Max.	Unit	Remark
Phase Error Between Channels					
PF=0.8 Capacitive		±0.05		Degree	
PF=0.5 Inductive		±0.05		Degree	
Active Energy Metering Error		0.1		%	Dynamic Range 5000:1 @ 25°C Fundamental frequency deviation within ± 25%
Active Energy Metering Bandwidth		3.2		kHz	
Reactive Energy Metering Error		0.1		%	Dynamic Range 5000:1 @ 25°C Fundamental frequency deviation within ± 25%
Reactive Energy Metering Bandwidth		1.6		kHz	
VRMS Metering Error		1		%	Dynamic Range 2000:1 @ 25°C Fundamental frequency deviation within ± 25%
VRMS Metering		3.2		kHz	

Parameter	Min.	Typ.	Max.	Unit	Remark
Bandwidth					
IRMS Metering Error		1		%	Dynamic Range 5000:1 @ 25°C Fundamental frequency deviation within ± 25%
IRMS Metering Bandwidth		3.2		KHz	
Instantaneous value refresh time (t _{ivr})		10/20		ms	Effective value
		20/40		ms	Power value
Stabilization time of instantaneous value		3* t _{ivr}		ms	
Average value refresh time (t _{avr})		40/80/320/640		ms	Effective value
		80/160/320/640		ms	Power value
Stabilization time of average value		3* t _{avr}		ms	
Frequency Measurement					
Range	40		70	Hz	
Error		0.01		Hz	
Analog Input					
Maximum Signal Level			±200	mV	Peak value
ADC					
DC Offset			10	mV	
Resolution		23		Bit	Sign bit is included.
On-chip Reference					
Reference Error	-20		20	mV	@ 25°C
Power Supply Rejection Ratio		92		dB	
Temperature Coefficient		10	30	ppm/° C	
Output Voltage		1.208		V	
Power Supply					
VDD33	2.6	3.3	3.6	V	
Power-Down Detection Threshold	2.6	2.8	3.05	V	

Parameter	Min.	Typ.	Max.	Unit	Remark
Digital Power Supply (DVCC)					
Voltage		1.5		V	
CTI					
RCH frequency	-20%	6.5536	+20%	MHz	
Logic Output TX					
Output High Voltage, V _{OH}	2.4		V _{DD}	V	
Output Low Voltage, V _{OL}	0		0.4	V	
Logic Input RX					
Input High Voltage, V _{INH}	2.0		V _{DD} +0.3	V	
Input Low Voltage, V _{INL}	-0.3		0.8	V	
Input Current, I _{IN}			1	μA	
Input Capacitance, C _{IN}			10	pF	
Baud Rate	1200		19200	bps	Automatic baud rate adaption
SPI Data Rate			800	KHz	Related to system CLK, the highest speed is one sixteenth of system CLK.

1.4 Absolute Maximum Ratings

Table4. Absolute maximum ratings

Parameter	Mnemonic	Min.	Max.	Unit	Description
Analog Power Supply	VDD	-0.3	4	V	To ground.
Digital Power Supply	DVCC	-0.3	+1.98	V	To ground.
Analog Input Voltage	IAP/IAN/IBP/IBN	-0.3	3.3	V	To ground.
Analog Input Voltage	UP/UN	-0.3	3.3	V	To ground.
VDD setup speed	S _{VDD}	3.3V/s	1V/μs		
Operating Temperature		-40	+105	°C	
Storage Temperature		-55	+150	°C	

2 Registers

All register will be reset to default value which are hexadecimal when V93XX is in the reset state. There are three kinds of reset conditions, including external pin reset, global software reset, and RX reset.

2.1 Registers List

Table5. Register list

Register	Type	Address	Description	Default
ANA_CTRL0	R/W	0x00	Analog Control Register 0.	0x00000000
ANA_CTRL1	R/W	0x01	Analog Control Register 1.	0x00000000
DSP_CTRL0	R/W	0x02	Metering Control Register 0.	0x00000000
DSP_CTRL1	R/W	0x03	Metering Control Register 1.	0x00000000
DSP_CTRL2	R/W	0x04	Metering Control Register 2.	0x00000000
DSP_CTRL3	R/W	0x05	Metering Control Register 3.	0x00000000
DSP_CTRL4	R/W	0x06	Metering Control Register 4.	0x00000000
DSP_CTRL5	R/W	0x07	Metering Control Register 5.	0x00000000
DSP_DAT_PA	R	0x08	Instantaneous Active Power of channel A.	--
DSP_DAT_QA	R	0x09	Instantaneous Reactive Power of channel A.	--
DSP_DAT_SA	R	0x0A	Instantaneous Apparent Power of channel A.	--
DSP_DAT_PB	R	0x0B	Instantaneous Active Power of channel B.	--
DSP_DAT_QB	R	0x0C	Instantaneous Reactive Power of channel B.	--
DSP_DAT_SB	R	0x0D	Instantaneous Apparent Power of channel B.	--
DSP_DAT_RMS0U A	R	0x0E	Instantaneous RMS of Voltage.	--
DSP_DAT_RMS0IA	R	0x0F	Instantaneous RMS of current A.	--
DSP_DAT_RMS0IB	R	0x10	Instantaneous RMS of Current B.	--
DSP_DAT_CH1	R	0x11	Instantaneous Value of Fundamental wave of Channel 1.	--
DSP_DAT_CH2	R	0x12	Instantaneous Value of Fundamental wave of Channel 2.	--
DSP_DAT_PA1	R	0x13	Average Active Power of Channel A.	--

DSP_DAT_QA1	R	0x14	Average Reactive Power of Channel A.	--
DSP_DAT_SA1	R	0x15	Average Apparent Power of Channel A.	--
DSP_DAT_PB1	R	0x16	Average Active power of Channel B.	--
DSP_DAT_QB1	R	0x17	Average Reactive power of Channel B.	--
DSP_DAT_SB1	R	0x18	Average Apparent Power of Channel B.	--
DSP_DAT_RMS1U	R	0x19	Average RMS of Voltage.	--
DSP_DAT_RMS1IA	R	0x1A	Average RMS of Current A.	--
DSP_DAT_RMS1IB	R	0x1B	Average RMS of Current B.	--
DSP_DAT_CH1_AVG	R	0x1C	Average value of Fundamental wave of Channel 1.	--
DSP_DAT_CH2_AVG	R	0x1D	Average value of Fundamental wave of Channel 2.	--
DSP_DAT_RMSU_AVG	R	0x1E	Average RMS of Voltage for 10 or 12 cycles (chosed by line frequency).	--
DSP_DAT_RMSIA_AVG	R	0x1F	Average RMS of Current IA for 10 or 12 cycles (chosed by line frequency).	--
DSP_DAT_RMSIB_AVG	R	0x20	Average RMS of Current IB for 10 or 12 cycles (chosed by line frequency).	--
DSP_DAT_FRQ	R	0x21	Line Frequency.	--
DSP_DAT_DCU	R	0x22	DC value of voltage channel.	--
DSP_DAT_DCIA	R	0x23	DC value of current channel A.	--
DSP_DAT_DCIB	R	0x24	DC value of Current channel B.	--
DSP_CFG_CALI_PA	R/W	0x25	To set gain calibration for the active power A.	0x00000000
DSP_CFG_DC_PA	R/W	0x26	To set offset calibration for the active power A.	0x00000000
DSP_CFG_CALI_QA	R/W	0x27	To set gain calibration for Reactive power A.	0x00000000
DSP_CFG_DC_QA	R/W	0x28	To set offset calibration for Reactive power A.	0x00000000
DSP_CFG_CALI_PB	R/W	0x29	To set gain calibration for Active power B.	0x00000000
DSP_CFG_DC_PB	R/W	0x2A	To set offset calibration for Active power B.	0x00000000
DSP_CFG_CALI_QB	R/W	0x2B	To set gain calibration for Reactive power B.	0x00000000
DSP_CFG_DC_QB	R/W	0x2C	To set offset calibration for Reactive power B.	0x00000000
DSP_CFG_CALI_RMSU	R/W	0x2D	To set gain calibration for Voltage RMS.	0x00000000

DSP_CFG_RMS_DCU	R/W	0x2E	To set offset calibration for Voltage RMS.	0x00000000
DSP_CFG_CALI_RMSIA	R/W	0x2F	To set gain calibration for Current RMS A.	0x00000000
DSP_CFG_RMS_DCIA	R/W	0x30	To set offset calibration for Current RMS A.	0x00000000
DSP_CFG_CALI_RMSIB	R/W	0x31	To set gain calibration for Current RMS B.	0x00000000
DSP_CFG_RMS_DCI B	R/W	0x32	To set offset calibration for Current RMS B.	0x00000000
DSP_CFG_PHC	R/W	0x33	Phase Error Calibration Register. [10:0]= phase error calibration value for channel A [26:16]= phase error calibration value for channel B, where the range is from -766~767.	0x00000000
DSP_CFG_DCU	R/W	0x34	To set the DC calibration for the voltage channel.	0x00000000
DSP_CFG_DCIA	R/W	0x35	To set the DC calibration for the current channel A.	0x00000000
DSP_CFG_DCIB	R/W	0x36	To set the DC calibration for the current channel B.	0x00000000
DSP_CFG_BPF	R/W	0x37	Band-pass filter coefficient. Related to setting the DSP_MODE by Bit[7:4] of metering control register 0 (0x02,DSP_CTRL0). Setting 0x806764B6 at DSP_MODE=0, 1, 2; Setting 0x80DD7A8C at DSP_MODE=6, 7; Setting 0x82B465F0 at DSP_MODE=8. The frequency of other modes would be not supported to measure, so setting to 0x0.	0x00000000
DSP_CFG_CKSUM	R/W	0x38	Configuration register for checksum.	0x00000000
EGY_PROCTH	R/W	0x39	Anti-creep threshold for energy accumulator. When the accumulated value of the anti-creep energy accumulator over this threshold and the accumulated value of the high-speed energy accumulator under this threshold, the accumulated value of the	0x00000000

			high-speed energy accumulator will be cleared.	
EGY_PWRTH	R/W	0x3A	Accumulation threshold for energy accumulator. Because the energy accumulator was 46Bit, the accumulated value of the high-speed energy accumulator equals to this threshold*16384; the accumulated value of the low-speed energy accumulator equals to this value*4.	0x00000000
EGY_CONST1	R/W	0x3B	Energy accumulator 1 accumulating constant.	0x00000000
EGY_OUT1L	R/W	0x3C	Energy accumulator 1 accumulating lower bit.	0x00000000
EGY_OUT1H	R/W	0x3D	Energy accumulator 1 accumulating higher bit. Effective for lower 14 bit.	0x00000000
EGY_CFCNT1	R	0x3E	Energy accumulator 1 pulse counter.	0x00000000
EGY_CONST2	R/W	0x3F	Energy accumulator 2 accumulating constant.	0x00000000
EGY_OUT2L	R/W	0x40	Energy accumulator 2 accumulating lower bit.	0x00000000
EGY_OUT2H	R/W	0x41	Energy accumulator 2 accumulating higher bit. Effective for lower 14 bit.	0x00000000
EGY_CFCNT2	R	0x42	Energy accumulator 2 pulse counter.	0x00000000
EGY_CONST3	R/W	0x43	Energy accumulator 3 accumulating constant.	0x00000000
EGY_OUT3	R/W	0x44	Energy accumulator 3 accumulating value.	0x00000000
EGY_CFCNT3	R	0x45	Energy accumulator 3 pulse counter.	0x00000000
EGY_CONST4	R/W	0x46	Energy accumulator 4 accumulating constant.	0x00000000
EGY_OUT4	R/W	0x47	Energy accumulator 4 accumulating value.	0x00000000
EGY_CFCNT4	R	0x48	Energy accumulator 4 pulse counter.	0x00000000
EGY_CONST5	R/W	0x49	Energy accumulator 5 accumulating constant.	0x00000000
EGY_OUT5	R/W	0x4A	Energy accumulator 5 accumulating value.	0x00000000
EGY_CFCNT5	R	0x4B	Energy accumulator 5 pulse counter.	0x00000000
EGY_CONST6	R/W	0x4C	Energy accumulator 6 accumulating constant.	0x00000000

EGY_OUT6	R/W	0x4D	Energy accumulator 6 accumulating value.	0x00000000
EGY_CFCNT6	R	0x4E	Energy accumulator 6 pulse counter.	0x00000000
EGY_CONST7	R/W	0x4F	Energy accumulator 7 accumulating constant.	0x00000000
EGY_OUT7	R/W	0x50	Energy accumulator 7 accumulating value.	0x00000000
EGY_CFCNT7	R	0x51	Energy accumulator 7 pulse counter.	0x00000000
EGY_CONST8	R/W	0x52	Energy accumulator 8 accumulating constant.	0x00000000
EGY_OUT8	R/W	0x53	Energy accumulator 8 accumulating value.	0x00000000
EGY_CFCNT8	R	0x54	Energy accumulator 8 pulse counter.	0x00000000
DSP_OV_THL	R/W	0x55	To set the lower threshold for the power-creep detection.	0x00000000
DSP_OV_THH	R/W	0x56	To set the upper threshold for the power-creep detection.	0x00000000
DSP_SWELL_THL	R/W	0x57	To set the lower threshold for the voltage swell.	0x00000000
DSP_SWELL_THH	R/W	0x58	To set the upper threshold for the voltage dip.	0x00000000
DSP_DIP_THL	R/W	0x59	To set the lower threshold for the voltage dip.	0x00000000
DSP_DIP_THH	R/W	0x5A	To set the upper threshold for the voltage dip.	0x00000000
FD_OVTH	R/W	0x5B	To set over-voltage threshold for fast detection. Bit width is 30bit.	0x00000000
FD_LVTH	R/W	0x5C	To set under-voltage threshold for fast detection. Bit width is 30bit.	0x00000000
FD_IA_OCTH	R/W	0x5D	To set over-current threshold in current channel A for fast detection. Bit width is 30bit.	0x00000000
FD_IA_LCTH	R/W	0x5E	To set under-current threshold in current channel A for fast detection. Bit width is 30bit.	0x00000000
FD_IB_OCTH	R/W	0x5F	To set over-current threshold in current channel B for fast detection. Bit width is 30bit.	0x00000000
FD_IB_LCTH	R/W	0x60	To set under-current threshold in current channel B for fast detection. Bit width is 30bit.	0x00000000
DSP_PHS_STT	R/W	0x61	To control the phase measurement. Enable	--

			phase measurement once for writing operation.	
DSP_PHS_U	R	0x62	Voltage phase.	1
DSP_PHS_UN	R	0x63	Voltage waveform data which before zero-crossing.	0
DSP_PHS_UP	R	0x64	Voltage waveform data which after zero-crossing.	0x80000000
DSP_PHS_I	R	0x65	Current phase.	1
DSP_PHS_IN	R	0x66	Current waveform data which before zero-crossing.	0
DSP_PHS_IP	R	0x67	Current waveform data which after zero-crossing.	0x80000000
DAT_WAVE	R	0x69	Waveform data reading. It can repeatable reading the address and obtain the overall waveform data. If there is no need to read all data, it would be reset the bit 31 of DSP_CTRL5 to read address.	0
DAT_SWELL_CNT	R/C	0x6A	Voltage swell time records, half-wave as unit. Effective as 24bit. Writing any value into this address would be clear this counter to zero.	0
DAT_DIP_CNT	R/C	0x6B	Voltage dip time records, half wave as unit. Effective as 24bit. Writing any value into this address would be clear this counter to zero.	0
SYS_SFTRST	W	0x6C	Software reset register. Writing 0x4572beaf into this address would be happen software reset once.	--
SYS_BAUDCNT1	R	0x70	This register stores the system clock count value of the first bit of the UART frame header sent by V93XX.	--
SYS_BAUDCNT8	R	0x71	This register stores the system clock count value of the 8 bits of the UART frame header received by V93XX.	--
SYS_INTSTS	R/C	0x72	Interrupt status register.	--
SYS_INTEN	R/W	0x73	Interrupt enable register.	0x00000000
SYS_STS	R	0x74	System status register.	--
SYS_MISC	R/W	0x75	System control register.	--
SYS_BLK0_ADDR	R/W	0x79	Register for block reading address 0.	0
SYS_BLK1_ADDR	R/W	0x7A	Register for block reading address 1.	0

SYS_BLK2_ADDR	R/W	0x7B	Register for block reading address 2.	0
SYS_BLK3_ADDR	R/W	0x7C	Register for block reading address 3.	0
SYS_IOCFGX0	R/W	0x7D	Output configuration register for P0, P1, P2 and P3.	0
SYS_IOCFGX1	R/W	0x7E	Output configuration register for P4, P5 and P6.	0
SYS_VERSION	R	0x7F	Present hardware version.	--
DSP_CTRL6	R/W	0x80	Measurement control register 6	0
FUND_CALI_PA	R/W	0x81	To set gain calibration for fundamental active power A	0x00000000
FUND_DC_PA	R/W	0x82	Fundamental active power A small signal correction	0x00000000
FUND_CALI_QA	R/W	0x83	To set gain calibration for fundamental reactive power A	0x00000000
FUND_DC_QA	R/W	0x84	Fundamental reactive power A small signal correction	0x00000000
FUND_CALI_PB	R/W	0x85	To set gain calibration for fundamental active power B	0x00000000
FUND_DC_PB	R/W	0x86	Fundamental active power B small signal correction	0x00000000
FUND_CALI_QB	R/W	0x87	To set gain calibration for fundamental reactive power B	0x00000000
FUND_DC_QB	R/W	0x88	Fundamental reactive power B small signal correction	0x00000000
FUND_CALI_RMS U	R/W	0x89	To set gain calibration for RMS of fundamental voltage	0x00000000
FUND_RMS_DCU	R/W	0x8a	To set gain calibration for RMS of fundamental voltage small signal	
FUND_CALI_RMSI A	R/W	0x8b	To set gain calibration for RMS ratio of fundamental current A	
FUND_RMS_DCIA	R/W	0x8c	To set gain calibration for fundamental current A RMS small signal	
FUND_CALI_RMSI B	R/W	0x8d	To set gain calibration for RMS ratio of fundamental current B	
FUND_RMS_DCIB	R/W	0x8e	To set gain calibration for fundamental current B RMS small signal	
DIP_SWELL_CTRL	R/W	0x8f	Voltage surge control register	
SWELL_REG_MAX_CNT	R/C	0x90	The time recording register for the voltage surge reaching maximum value	

DIP_REG_MIN_CN T	R/C	0x91	The time recording register for the voltage dip reaching minimum value	
SWELL_REG_MAX	R	0x92	Maximum value of voltage surge	
DIP_REG_MIN	R	0x93	Minimum value of voltage dip	
ZERO_TH_U	R/W	0x94	Voltage zero crossing detection threshold register	
ZERO_TH_I	R/W	0x95	Current zero crossing detection threshold register	

2.2 Analog Control Registers

When RSTN pin reset, RX reset, or global software reset occurs, all analog control registers will be reset to the default value. The default value in the following tables of this section are in format of hexadecimal.

The address range of Analog Control Register is 0x00~0x01 which all is readable and writable. Also, all the metering control registers need to be configuration verification and self-checking.

2.2.1 ANA_CTRL0 Register

Table6. Analog Control Register 0 (0x00, ANA_CTRL0)

0x00, R/W, Analog Control Register 0, ANA_CTRL0			
Bit		Default Value	Description
31:18	Reserved	0	These bits must hold its default value for proper operation.
17:14	Reserved	0	These bits must hold its default value for proper operation.
13	MEA	0	To select the analog input for Channel IB. 0: differential IB input 1: Reserved
12	Reserved	0	The bit must hold its default value for proper operation.
11	SHORT_I	0	Current IA channel ADC input short circuit. 0: short circuit 1: Normal
10	SHORT_V	0	Voltage U channel ADC input short circuit. 0: short circuit 1: Normal

0x00, R/W, Analog Control Register 0, ANA_CTRL0			
Bit		Default Value	Description
9:0	Reserved	0	These bits must hold its default value for proper operation.

2.2.2 ANA_CTRL1 Register

Table7. Analog Control Register 1 (0x01, ANA_CTRL1)

0x01, R/W, Analog Control Register 1, ANA_CTRL1			
Bit		Default Value	Description
31:30	ADCKSEL[1:0]	0	The options of clock frequency divider rate for the ADC 00 corresponds to 819.2 KHz. 00: ×1 01: ×2 10: ×1/4 11: ×1/2
29:24	RCHTRIM[5:0]	0	To adjust the 6.5M RC frequency. The default value of 0b000000 is not adjusted. 0b000001~0b011111: For each additional bit, the clock frequency increases by 1.25% compared to the frequency at 0b000000; 0b111111~0b100000: For each bit decrease, the clock frequency decreases by 1.25% compared to the frequency at 0b000000.
23	Reserved	0	The bit must hold its default value for proper operation.
22	RCCLK_PD	0	To enable the 6.5M RC oscillator. 0: enable 1: disable This bit must be set to 0 for proper operation.
21:15	Reserved	0	These bits must hold its default value for proper operation.
14:12	GIB[2:0]	0	To adjust the gain of current ADC in the channel B. 000: 4 001: 1 010: 32 011: 16 100/101/110/111: prohibited

0x01, R/W, Analog Control Register 1, ANA_CTRL1			
Bit		Default Value	Description
			GIB[2:0] is recommended set to 000 for proper operation.
11	GU	0	To adjust the gain of voltage ADC. 0: 8 1: 4 This bit must be set to 0 for proper operation.
10:8	GIA[2:0]	0	To adjust the gain of current ADC in the channel A. 000: 32 001: 16 010: 4 011: 1 100~111: prohibited GIA[2:0] is recommended set to 000 for proper operation.
7	XRST_PD	0	The external input CTI clock enable. 0: enable 1: disable
6:5	Reserved	0	These bits must hold its default value for proper operation.
4:3	RESTL[1:0]	0	To roughly adjust the temperature coefficient of the Bandgap circuit. 00: 0 ppm 01: -58 ppm 10: +111 ppm 11: +56 ppm
2:0	REST[2:0]	0	To finely adjust the temperature coefficient of the Bandgap circuit. 000: 0 ppm 001: +7 ppm 010: +14 ppm 011: +28 ppm 100: -32 ppm 101: -21 ppm 110: -14 ppm 111: -7 ppm

2.3 System Control & Status Register

When RSTN pin reset, RX reset, or global software reset occurs, all system control registers will be reset to the default value. The default value in the following tables of this section are in format of hexadecimal.

In the V93XX, the mainly functions of System Control Register is controlling interface, interrupt, RAM, and IO output. SYS_INTEN (0x73) controls enable interruption, SYS_INTSYS (0x72) is interrupted status register. Bit[4: 0] of SYS_MISC (0x75) are used for configuring the interface operation, interrupting pin output whether reverse, whether turn off the energy accumulator when power down and whether turn off the energy accumulator when in wrong calibration. SYS_RAMADDR (0x77) is controlling internal RAM address. SYS_RAMDATA is internal RAM data registers. SYS_BLK0_ADDR~SYS_BLK3_ADDR are blocked reading address. SYS_IOCFIGX0~SYS_IOCFIGX1 are the control register of IO output

2.3.1 SYS_BAUDCNT1 Register

Table8. UART transmitting data 1bit count value (0x70, SYS_BAUDCNT1)

0x70, UART transmitting data 1bit count value, SYS_BAUDCNT1				
bit		R/W	Default Value	Description
31:1	-	-	-	Reserved.
4				
13:0	BAUDCN T1	R		This register stores the system clock count value of the first bit of the UART frame header sent by V93XX.

2.3.2 SYS_BAUDCNT8 Register

Table9. UART receiving data 8bit count value (0x71, SYS_BAUDCNT8)

0x71, UART receiving data 8bit count value, SYS_BAUDCNT8				
Bit		R/W	Default Value	Description
31:17	-	-	-	Reserved.
16:0	BAUDCNT8	R		This register stores the system clock count value of the 8 bits of the UART frame header received by V93XX.

2.3.3 SYS_INTSTS Register

Table10. System Interrupt Register (0x72, SYS_INTSTS)



0x72, System Interrupt Register, SYS_INTSTS				
Bit		R/W	Default value	Description
31:3	-	-	-	Reserved.
0	-	-	-	Reserved.
29	EGY2OV	R/C	0	Flag bit for high-speed energy accumulator 2 overflow interrupt Read 0: high-speed energy accumulator overflow did not happen Read 1: high-speed energy accumulator overflow happened Write 0: no effects Write 1: clear the bit
28	EGY1OV	R/C	0	Flag bit for high-speed energy accumulator 1 overflow interrupt Read 0: high-speed energy accumulator overflow did not happen Read 1: high-speed energy accumulator overflow happened Write 0: no effects Write 1: clear the bit
27	UDIP	R/C	0	Flag bit for the voltage dip. Read 0: the voltage dip did not happen Read 1: the voltage dip happened Write 0: no effects Write 1: clear the bit
26	USWELL	R/C	0	Flag bit for the voltage swell. Read 0: the voltage swell did not happen Read 1: the voltage swell happened Write 0: no effects Write 1: clear the bit
25	IBLC	R/C	0	Flag bit for the IB under-current. Read 0: IB under-current did not happen Read 1: IB under-current happen Write 0: no effects Write 1: clear the bit
24	IBOC	R/C	0	Flag bit for the IB over-current. Read 0: IB over-current did not happen

0x72, System Interrupt Register, SYS_INTSTS				
Bit		R/W	Default value	Description
				Read 1: IB over-current happened Write 0: no effects Write 1: clear the bit
23	IALC	R/C	0	Flag bit for the IA under-current. Read 0: IA under-current did not happen Read 1: IA under-current happened Write 0: no effects Write 1: clear the bit
22	IAOC	R/C	0	Flag bit for the IA over-current. Read 0: IA over-current did not happen Read 1: IA over-current happened Write 0: no effects Write 1: clear the bit
21	ULV	R/C	0	Flag bit for the channel U under-voltage. Read 0: channel U under-voltage did not happen Read 1: channel U under-voltage happened Write 0: no effects Write 1: clear the bit
20	UOV	R/C	0	Flag bit for the channel U over-voltage. Read 0: channel U over-voltage did not happen Read 1: channel U over-voltage happened Write 0: no effects Write 1: clear the bit
19	SPI_ERR	R/C	0	Flag bit for the SPI communication error. When any one of condition below happens, the bit will set to "1". A, SPI overtime (rising edge of each 2 SPCK needs to shorter than 20 ms) B, SPI CLK counter error (the number of clocks not equals to 48 at 4-wire SPI) Read 0: SPI error did not happen Read 1: SPI error happened write 0: no effects write 1: clear the bit

0x72, System Interrupt Register, SYS_INTSTS				
Bit		R/W	Default value	Description
18:1	Reserved	-	-	-
7				
16	UART_ERR	R/C	0	<p>Flag bit for the UART communication error. When any one of condition as below happens, the bit will set to "1".</p> <p>A: UART overtime (each 2 Bytes needs to shorter than 20 ms)</p> <p>B: UART checksum bit error</p> <p>C: UART checksum byte error</p> <p>Read 0: UART error did not happen</p> <p>Read 1: UART happened</p> <p>write 0: no effects</p> <p>write 1: clear the bit</p>
15	DMA_FINISH	R/C	0	<p>Flag bit for active waveform uploading finished.</p> <p>Read 0: active waveform uploading did not finish</p> <p>Read 1: active waveform uploading finished</p> <p>Write 0: no effects</p> <p>Write 1: clear the bit</p>
14	CKERR	R/C		<p>Flag bit for checksum error. Checksum from correct to error, it would be interrupted.</p> <p>Read 0: checksum error did not happen</p> <p>Read 1: checksum error happened</p> <p>Write 0: no effects</p> <p>Write 1: clear the bit</p>
13	HSE_FAIL	R/C		<p>Flat bit for CTI external input clock status.</p> <p>Read 0: CTI external input clock error has occurred I did not happen</p> <p>Read 1: CTI external input clock error has happened</p> <p>Write 0: no effects</p> <p>Write 1: clear the bit</p> <p>This flag bit will only be raised after using an external clock and the external clock is missing for a certain amount of time.</p>

0x72, System Interrupt Register, SYS_INTSTS				
Bit		R/W	Default value	Description
12	REF_ERR	R/C		Flag bit for reference error Read 0: reference error did not happen Read 1: reference error happened Write 0: no effects Write 1: clear the bit
11	BIST_ERR	R/C		Flag bit for BIST error Read 0: BIST error did not happen Read 1: BIST error happened Write 0: no effects Write 1: clear the bit
10	ISIGN	R/C		Flag bit for current zero-crossing, it could to select the channel IA or IB by bit20 of metering control register, and to select the direction of zero-crossing by bit19~bit18 of metering control register (0x03,DSP_CTRL1). Read 0: current zero-crossing did not happen Read 1: current zero-crossing happened Write 0: no effects Write 1: clear the bit
9	USIGN	R/C		Flag bit for voltage zero-crossing, it could to select the direction of zero-crossing by bit19~bit18 of DSP_CTRL1 Read 0: voltage zero-crossing did not happen Read 1: voltage zero-crossing happened Write 0: no effects Write 1: clear the bit
8	WAVE_OVERFLOW	R/C	0	Flag bit for waveform storage overflow. Read 0: waveform storage did not overflow Read 1: waveform storage already overflowed Write 0: no effects Write 1: clear the bit
7	WAVE_STORE	R/C	0	Flag bit for waveform storage status. Read 0: waveform storage did not finish Read 1: waveform storage already finished Write 0: no effects

0x72, System Interrupt Register, SYS_INTSTS				
Bit		R/W	Default value	Description
				Write 1: clear the bit
6	WAVE_UPD	R/C	0	Flag bit for waveform updating. Read 0: waveform data did not update Read 1: waveform data updated Write 0: no effects Write 1: clear the bit
5	CURRMS_UPD	R/C	0	Flag bit for instantaneous RMS data updating. Read 0: instantaneous RMS data did not update Read 1: instantaneous RMS data updated Write 0: no effects Write 1: clear the bit
4	AVGRMS_UPD	R/C	0	Flag bit for average RMS data updating. Read 0: average RMS data did not update Read 1: average RMS data updated Write 0: no effects Write 1: clear the bit
3	CURPOWER_UPD	R/C	0	Flag bit for instantaneous power data updating. Read 0: instantaneous power data did not update Read 1: instantaneous power data updated Write 0: no effects Write 1: clear the bit
2	AVGPOWER_UPD	R/C	0	Flag bit for average power data updating. Read 0: average power data did not update Read 1: average power data updated Write 0: no effects Write 1: clear the bit
1	INTPDN	R/C	0	Flag bit for power down event. When the power input (VDD) is lower than 2.8V ($\pm 7\%$), it would be triggered. Read 0: power down did not happen Read 1: power down happened Write 0: no effects

0x72, System Interrupt Register, SYS_INTSTS				
Bit		R/W	Default value	Description
				Write 1: clear the bit
0	INTUPHSDONE	R/C	0	Flag bit for Phase measurement finished. This bit will clear automatically when starts to phase measurement. Read 0: phase measurement did not finish Read 1: phase measurement already finished Write 0: no effects Write 1: clear the bit

2.3.4 SYS_INTEN Register

Table11. System Interrupt Enable Register (0x73, SYS_INTEN)

0x73, System Interrupt Enable Register, SYS_INTEN				
Bit		R/W	Default Value	Description
31:3 0	Reserved		0	These bits must hold its default value for proper operation.
29	EGY2OV	R/W	0	Interrupt for high-speed energy accumulator 2 overflow 0: disable interrupt 1: enable interrupt
28	EGY1OV	R/W	0	Interrupt for high-speed energy accumulator 1 overflow 0: disable interrupt 1: enable interrupt
27	UDIP	R/W	0	Interrupt for the voltage dip. 0: disable interrupt 1: enable interrupt
26	USWELL	R/W	0	Interrupt for voltage swell. 0: disable interrupt 1: enable interrupt
25	IBLC	R/W	0	Interrupt for IB under-current. 0: disable interrupt 1: enable interrupt
24	IBOC	R/W	0	Interrupt for IB over-current.

0x73, System Interrupt Enable Register, SYS_INTEN				
Bit		R/W	Default Value	Description
				0: disable interrupt 1: enable interrupt
23	IALC	R/W	0	Interrupt for IA under-current. 0: disable interrupt 1: enable interrupt
22	IAOC	R/W	0	Interrupt for IA over-current. 0: disable interrupt 1: enable interrupt
21	ULV	R/W	0	Interrupt for channel U under-voltage. 0: disable interrupt 1: enable interrupt
20	UOV	R/W	0	Interrupt for channel U over-voltage. 0: disable interrupt 1: enable interrupt
19	SPI_ERR	R/W	0	Interrupt for SPI transmission error. 0: disable interrupt 1: enable interrupt
18:1 7	Reserved			These bits must hold its default value for proper operation.
16	UART_ERR	R/W	0	Interrupt for UART transmission error. 0: disable interrupt 1: enable interrupt
15	DMA_FINISH	R/W	0	Waveform uploading finished. 0: disable interrupt 1: enable interrupt
14	CKERR	R/W	0	Interrupt for checksum error. 0: disable interrupt 1: enable interrupt
13	HSE_FAIL	R/W	0	Interrupt for CTI external input clock error. 0: disable interrupt 1: enable interrupt
12	REF_ERR	R/W	0	Interrupt for reference error. 0: disable interrupt 1: enable interrupt
11	BOST_ERR	R/W	0	Interrupt for BIST error.

0x73, System Interrupt Enable Register, SYS_INTEN				
Bit		R/W	Default Value	Description
				0: disable interrupt 1: enable interrupt
10	ISIGN	R/W	0	Interrupt for the current zero-crossing. 0: disable interrupt 1: enable interrupt
9	USIGN	R/W	0	Interrupt for the voltage zero-crossing. 0: disable interrupt 1: enable interrupt
8	WAVE_OVERFLOW	R/W	0	Interrupt for the Waveform storage overflow. 0: disable interrupt 1: enable interrupt
7	WAVE_STORE	R/W	0	Interrupt for the Waveform storage status. 0: disable interrupt 1: enable interrupt
6	WAVE_UPD	R/W	0	Interrupt for the Waveform data updating. 0: disable interrupt 1: enable interrupt
5	CURRMS_UPD	R/W	0	Interrupt for the Instantaneous RMS data updating. 0: disable interrupt 1: enable interrupt
4	AVGRMS_UPD	R/W	0	Interrupt for the average RMS data updating. 0: disable interrupt 1: enable interrupt
3	CURPOWER_UPD	R/W	0	Interrupt for the Instantaneous power data updating. 0: disable interrupt 1: enable interrupt
2	AVGPOWER_UPD	R/W	0	Interrupt for the Average power data updating. 0: disable interrupt 1: enable interrupt
1	INTPDN	R/W	0	Interrupt for the Power down. 0: disable interrupt 1: enable interrupt

0x73, System Interrupt Enable Register, SYS_INTEN				
Bit		R/W	Default Value	Description
0	INTUPHSDON E	R/W	0	Interrupt for the Phase measurement finished. 0: disable interrupt 1: enable interrupt

2.3.5 SYS_STS Register

Table12. System Status Register (0x74, SYS_STS)

0x74, System Status Register, SYS_STS				
Bit		R/W	Default Value	Description
31	-	-	-	Reserved
30	UDIP	R	0	Status bit for the voltage dip. 0: not happened 1: happened
29	USWELL	R	0	Status bit for voltage swell. 0: not happened 1: happened
28	IBLC	R	0	Status bit for IB under-current. 0: not happened 1: happened
27	IBOC	R	0	Status bit for IB over-current. 0: not happened 1: happened
26	IALC	R	0	Status bit for IA under-current. 0: not happened 1: happened
25	IAOC	R	0	Status bit for IA over-current. 0: not happened 1: happened
24	ULV	R	0	Status bit for channel U under-voltage. 0: not happened 1: happened
23	UOV	R	0	Status bit for channel U over-voltage. 0: not happened 1: happened

0x74, System Status Register, SYS_STS				
Bit		R/W	Default Value	Description
22:20	RST_SOURCE	R	-	Status bit for reset. 1: power on reset 2: external reset 3: RX low-level voltage reset 4: software reset Others are reserved.
19	CRP_OUT2	R	0	Status bit for power-creep detection for energy accumulator 2. 0: start 1: power-creep
18	CRP_OUT1	R	0	Status bit for power-creep detection for energy accumulator 1. 0: start 1: power-creep
17	SBCREEP	R	-	Status bit for no-load detection for apparent power Channel B. 0: start 1: power-creep
16	QBCREEP	R	-	Status bit for power-creep detection for reactive power Channel B. 0: start 1: power-creep
15	PBCREEP	R	-	Status bit for power-creep detection for active power Channel B. 0: start 1: power-creep
14	SACREEP	R	-	Status bit for power-creep detection for apparent power Channel A. 0: start 1: power-creep
13	QACREEP	R	-	Status bit for power-creep detection for reactive power Channel A. 0: start 1: power-creep

0x74, System Status Register, SYS_STS				
Bit		R/W	Default Value	Description
12	PACREEP	R	-	Status bit for power-creep detection for active power Channel A. 0: start 1: power-creep
11	QBSIGN	R	0	Sign bit for reactive power Channel B. Under the power-creep detection, no refresh the flag bit. 0: positive 1: negative
10	PBSIGN	R	0	Sign bit for active power Channel B. Under the power-creep detection, no refresh the flag bit. 0: positive 1: negative
9	QASIGN	R	0	Sign bit for reactive power Channel A. Under the power-creep detection, no refresh the flag bit. 0: positive 1: negative
8	PASIGN	R	0	Sign bit for active power Channel A. Under the power-creep detection, no refresh the flag bit. 0: positive 1: negative
7	-	-	-	Reserved
6	HSEFAIL	R	0	Status bit for CTI external input clock status. 0: normal 1: abnormal
5	BISTERR	R	0	Status bit for SRAM BIST. 0: SRAM BIST normal 1: SRAM BIST error
4	RAMINITIAL		0	Status bit for RAM initialization finished 0: failed 1: finished
3	PHSDONE		0	Status bit for Phase measurement finished 0: failed 1: finished

0x74, System Status Register, SYS_STS				
Bit		R/W	Default Value	Description
2	PD	R	0	Status bit for power down. When the power input (VDD) is lower than 2.8V ($\pm 7\%$), power down event happens. 0: VDD \geq 2.8V ($\pm 7\%$) 1: VDD < 2.8V ($\pm 7\%$)
1	REFLK	R	0	Status bit for the reference of ADC whether electric leaking. 0: ADC reference circuit normal 1: ADC reference circuit decrease is greater than 2.5%.
0	CHECKSUM	R	1	Status bit for Checksum. Checksum calculation address range: 0x0 ~ 0x7, 0x25 ~ 0x3A, 0x55 ~ 0x60, 0x80 0: checksum correct 1: checksum incorrect

2.3.6 SYS_MISC Register

Table13. System Control Register (0x75, SYS_MISC)

0x75, system Control Register, SYS_MISC				
Bit		R/W	Default Value	Description
31:2 5	Reserved	R	0	These bits must hold its default value for proper operation.
24:1 6	WAVE_STORE_CNT	R	0	Count value for Waveform storage.
15:6	Reserved		0	These bits must hold its default value for proper operation.
5	BIST_EGY_EN	R/W	0	When RAM self-test has error, force the energy accumulator and CF output to disable. 0: enable 1: disable The control bits for the energy accumulator and CF counter (Bit[15] and Bit[7:6]) in DSP_CTRL1 register will not change.

0x75, system Control Register, SYS_MISC				
Bit		R/W	Default Value	Description
				Although the DSP_CTRL1 register value has not changed, the energy accumulator and CF output functions will not be restored automatically and need to be opened manually by the user after the state returns to normal.
4	CK_EGY_EN	R/W	0	When checksum has error, force the energy accumulator and CF output to disable. 0: enable 1: disable The control bits for the energy accumulator and CF counter (Bit[15] and Bit[7:6]) in DSP_CTRL1 register will not change. Although the DSP_CTRL1 register value has not changed, the energy accumulator and CF output functions will not be restored automatically and need to be opened manually by the user after the state returns to normal.
3	PD_EGY_EN	R/W	0	When power-down, force the energy accumulator and CF output to disable. 0: enable 1: disable The control bits for the energy accumulator and CF counter (Bit[15] and Bit[7:6]) in DSP_CTRL1 register will not change. Although the DSP_CTRL1 register value has not changed, the energy accumulator and CF output functions will not be restored automatically and need to be opened manually by the user after the state returns to normal.
2	INTPOL	R/W	0	Reverse output on Interrupted pin. 0: interrupt pin triggered by high-level voltage, and default is low-level voltage. 1: interrupt pin triggered by low-level

0x75, system Control Register, SYS_MISC				
Bit		R/W	Default Value	Description
				voltage, and default is high-level voltage.
1	UARTBURSTEN	R/W	0	To enable the UART continue writing mode. 0: enable 1: disable
0	UARTAUTOEN	R/W	0	To enable baud rate self-adapting for UART. It suggests enabling before changing system CLK. 0: disable Baud rate self-adapting function. Baud rate self-adapting only for first time communication. 1: enable Baud rate self-adapting function. Baud rate self-adapting for every time communication.

2.3.7 SYS_BLKX Register

Table14. Block-reading Address Register 0 (0x79, SYS_BLK0_ADDR)

0x79, Block-reading Address Register 0, SYS_BLK0_ADDR				
Bit		R/W	Default Value	Description
31:24	ADDR 3	R/W	0	Block-reading address 3.
23:16	ADDR 2	R/W	0	Block-reading address 2.
15:8	ADDR 1	R/W	0	Block-reading address 1.
7:0	ADDR 0	R/W	0	Block-reading address 0.

Table15. Block-reading Address Register 1 (0x7A, SYS_BLK1_ADDR)

0x7A, Block-reading Address Register 1, SYS_BLK1_ADDR				
Bit		R/W	Default Value	Description
31:24	ADDR 7	R/W	0	Block-reading address 7.

0x7A, Block-reading Address Register 1, SYS_BLK1_ADDR				
Bit		R/W	Default Value	Description
23:16	ADDR6	R/W	0	Block-reading address 6.
15:8	ADDR5	R/W	0	Block-reading address 5.
7:0	ADDR4	R/W	0	Block-reading address 4.

Table16. Block-reading Address Register 2 (0x7B, SYS_BLK2_ADDR)

0x7B, Block-reading Address Register 2, SYS_BLK2_ADDR				
Bit		R/W	Default Value	Description
31:24	ADDR11	R/W	0	Block-reading address 11.
23:16	ADDR10	R/W	0	Block-reading address 10.
15:8	ADDR9	R/W	0	Block-reading address 9.
7:0	ADDR8	R/W	0	Block-reading address 8.

Table17. Block-reading Address Register 3 (0x7C, SYS_BLK3_ADDR)

0x7C, Block-reading Address Register 3, SYS_BLK3_ADDR				
Bit		R/W	Default Value	Description
31:24	ADDR15	R/W	0	Block-reading address 15.
23:16	ADDR14	R/W	0	Block-reading address 14.
15:8	ADDR13	R/W	0	Block-reading address 13.
7:0	ADDR12	R/W	0	Block-reading address 12.

2.3.8 SYS_IOCFCGX Register

Table18. IO Configuration Register 0 (0x7D, SYS_IOCFCGX0)

0x7D, IO Configuration Register 0, SYS_IOCFCGX0				
Bit		R/W	Default Value	Description
31:24	P3CFG	R/W	0	Configuration as the same as P0CFG.
23:16	P2CFG	R/W	0	Configuration as the same as P0CFG.
15:8	P1CFG	R/W	0	Configuration as the same as P0CFG.

0x7D, IO Configuration Register 0, SYS_IOCFCGX0				
Bit		R/W	Default Value	Description
7:0	P0CFG	R/W	0	Bit[7:6]: 00: as shown in the Table19, it can be configured the different combination interruption. 10: CF1 output. Bit[5:0] can be configured arbitrary value. 01: CF2 output. Bit[5:0] can be configured arbitrary value. 11: Actively energy accumulation data uploads. Bit[5:0] can be configured arbitrary value.

Table19. P0CFG Bit[5:0] Description

Bit[5:3]	Bit[2:0]	
0	0	High impedance.
0	1	Current zero-crossing interruption.
0	2	Voltage zero-crossing interruption.
0	3	Current zero crossing output square wave.
0	4	Voltage zero crossing output square wave.
0	5	High speed energy accumulator 1 overflow interrupt.
0	6	High speed energy accumulator 2 overflow interrupt.
0	7	1 st type interruption.
1	0	Waveform refresh interruption.
1	1	Instantaneous RMS refresh interruption.
1	2	Average RMS refresh interruption.
1	3	Instantaneous power refresh interruption.
1	4	Average power refresh interruption.
1	5	Waveform storage finish interruption.
1	6	Waveform storage address overflow interruption.
1	7	Waveform data upload finish interruption.
2	0	IB channel under-current interruption.
2	1	IB channel over-current interruption.
2	2	IA channel under-current interruption.
2	3	IA channel over-current interruption.
2	4	Voltage Channel under-voltage interruption.
2	5	Voltage Channel over-voltage interruption.
2	6	Voltage dip interruption.

2	7	Voltage swell interruption.
3	0	Reference error.
3	1	CTI external input clock error.
3	2	SPI communication error interruption.
3	3	UART communication error interruption.
3	4	Power-down interruption.
3	5	Parameter self-checking error interruption.
3	6	Phase test finish interruption.
3	7	RAM self-checking error.
4	0	1 st type interruption.
4	1	2 nd type interruption.
4	2	3 rd type interruption.
4	others	4 th type interruption.
5	0	3 rd type interruption.
5	1	1 st and 2 nd type interruption.
5	2	1 st and 3 rd type interruption.
5	3	1 st and 4 th type interruption.
5	4	2 nd and 3 rd type interruption.
5	5	2 nd and 4 th type interruption.
5	6	3 rd and 4 th type interruption.
5	7	All interruption.
6	0	1 st , 2 nd and 3 rd type interruption.
6	1	1 st , 2 nd and 4 th type interruption.
6	2	1 st , 3 rd and 4 th type interruption.
6	3	2 nd , 3 rd and 4 th type interruption.
6	others	All interruption.
7	1	Active waveform updating for chip select of SPI, SPIMAS_SPCSN.
7	2	Active waveform updating for SPI clock, SPIMAS_SPCK.
7	4	Active waveform updating for SPI data, SPIMAS_SPDO.
7	others	Prohibited output.

While the IO interface is not configured (i.e. all zero), output is high impedance.

- 1st type interruption: current zero-crossing interruption, voltage zero-crossing interruption, high-speed energy accumulator 1/2 overflow interruption.
- 2nd type interruption: waveform refreshes interruption, instantaneous RMS refresh interruption, average RMS refreshes interruption, instantaneous power value refresh interruption, average power value refreshes interruption, waveform storage finish interruption, waveform storage overflow interruption and waveform data upload finished

interruption.

- 3rd type interruption: IB channel under-current interruption, IB channel over-current interruption, IA channel under-current interruption, IA channel over-current interruption, voltage channel under-voltage interruption, voltage channel over-voltage interruption, voltage dip interruption and voltage swell interruption, the end of voltage drop interruption, the end of voltage rise interruption.
- 4th type interruption: SPI communicating error interruption, UART communicating error interruption, parameters self-checking error interruption, phase measurement finished interruption, power-down interruption, reference error interruption, CTI external input clock error interruption and RAM self-checking error interruption.

Table20. IO Configuration Register 1 (0x7E, SYS_IOCFCGX1)

0x7E, IO Configuration Register 1, SYS_IOCFCGX1				
Bit		R/W	Default Value	Description
31:24	Reserved		0	These bits must hold its default value for proper operation.
23:16	P6CFG	R/W	0	Configuration as the same as P0CFG.
15:8	P5CFG	R/W	0	Configuration as the same as P0CFG.
7:0	P4CFG	R/W	0	Configuration as the same as P0CFG.

2.3.9 SYS_VERSION Register

Table21. Version Information Register (0x7F, SYS_VERSION)

0x7F, Version Information Register, SYS_VERSION				
Bit		R/W	Default Value	Description
31:0	VERSION	R	-	Present hardware version.

2.4 Metering Control Registers

When RSTN pin reset, RX reset, or global software reset occurs, all metering control registers will be reset to the default value. The default value in the following tables of this section are in format of hexadecimal.

All the metering control registers need to be configuration verification and self-checking.

2.4.1 DSP_CTRL0 Register

Table22. Metering Control Register 0 (0x02, DSP_CTRL0)

0x02, R/W, Metering Control Register 0, DSP_CTRL0				
Bit		R/W	Default Value	Description
31	CURDAT_RATE	R/W	0	Double refresh time for Instantaneous power value and RMS value. 0: refresh time for instantaneous power value is 20 ms and instantaneous RMS value is 10 ms. 1: refresh time for instantaneous power value is 40 ms and instantaneous RMS value is 20 ms.
30	Reserved		0	The bit must hold its default value for proper operation.
29:28	FRQ_SEL	R/W	0	Source comes from the register value of DSP_DAT_FRQ. 00: accumulation value for line frequency test value of 16 cycles (the default update time is 320 ms) 01: line frequency test value of 1 cycle (the default update time is 20 ms) 10: line frequency test value of 64 cycles (the default update time is 1280 ms) 11: Reserved
27	DC_METER_MODE	R/W	0	To enable the DC metering mode. 0: disable 1: enable
26:25	-	-	0	The bit must hold its default value for proper operation.
24	S_MODE	R/W	0	Source select for Apparent power calculation. 0: by RMS value 1: by power value
23:20	CFG_CHANNEL	R/W	0	Fundamental Channel selectable. 0: channel 1, fundamental active power A; channel 2, fundamental active power B 1: channel 1, fundamental active power A; channel 2, fundamental voltage RMS 2: channel 1, fundamental active power A;

0x02, R/W, Metering Control Register 0, DSP_CTRL0				
Bit		R/W	Default Value	Description
				channel 2, fundamental current RMS A 3: channel 1, fundamental active power A; channel 2, fundamental current RMS B 4: channel 1, fundamental active power B, channel 2, fundamental voltage RMS 5: channel 1, fundamental active power B; channel 2, fundamental current RMS A 6: channel 1, fundamental active power B; channel 2, fundamental current RMS B 7: channel 1, fundamental voltage RMS; channel 2, fundamental current RMS A 8: channel 1, fundamental voltage RMS, channel 2, fundamental current RMS B 9: channel 1, fundamental current RMS A; channel 2, fundamental current RMS B 10~15: the same as configured 0
19	QB_MODE	R/W	0	To select mode for Reactive power B. 0: total wave, reactive power 1: fundamental wave, reactive power
18	QA_MODE	R/W	0	To select mode for Reactive power A. 0: total wave, reactive power 1: fundamental wave, reactive power
17	PQ_HPFSEL	R/W	0	Calculate the total power whether pass high-pass filter. 0: pass 1: not pass When the Roche coil sampling switch is turned on, the Bit [17:13] of DSP_CTRL0 must be the same value, otherwise the Roche coil sampling is invalid.
16	FUND_HPFSEL	R/W	0	Calculate the fundamental data whether pass high-pass filter: 0: pass 1: not pass When the Roche coil sampling switch is turned on, the Bit [17:13] of DSP_CTRL0

0x02, R/W, Metering Control Register 0, DSP_CTRL0				
Bit		R/W	Default Value	Description
				must be the same value, otherwise the Roche coil sampling is invalid.
15	RMSU_HPFSEL	R/W	0	Calculate the total voltage RMS data whether pass high-pass filter: 0: pass 1: not pass When the Roche coil sampling switch is turned on, the Bit [17:13] of DSP_CTRL0 must be the same value, otherwise the Roche coil sampling is invalid.
14	RMSIA_HPFSEL	R/W	0	Calculate the total current IA RMS data whether pass high-pass filter: 0: pass 1: not pass When the Roche coil sampling switch is turned on, the Bit [17:13] of DSP_CTRL0 must be the same value, otherwise the Roche coil sampling is invalid.
13	RMSIB_HPFSEL	R/W	0	Calculate current IB RMS data whether pass high-pass filter: 0: pass 1: not pass When the Roche coil sampling switch is turned on, the Bit [17:13] of DSP_CTRL0 must be the same value, otherwise the Roche coil sampling is invalid.
12	RESPONSE_TIME	R/W	0	Metering data response time. 0: normal 1: 2 times
11:10	AVGRMS_RATE	R/W	0	Average RMS refresh time. 00: 40 ms 01: 80 ms 10: 320 ms 11: 640 ms
9:8	AVGPQ_RATE	R/W	0	Average power refresh time.

0x02, R/W, Metering Control Register 0, DSP_CTRL0				
Bit		R/W	Default Value	Description
				00: 40 ms 01: 80 ms 10: 320 ms 11: 640 ms
7:4	DSP_MODE	R/W	0	DSP Operating Mode. 0: 128 sampling points per cycle by DSP at 6.5536 MHz system clock 1: 64 sampling points per cycle by DSP at 6.5536 MHz system clock 2: 32 sampling points per cycle by DSP at 6.5536 MHz system clock. 3, 4, and 5: Reserved. 6: 64 sampling points per cycle by DSP at 3.2768 MHz system clock 7: 32 sampling points per cycle by DSP at 3.2768 MHz system clock 8: 32 sampling points per cycle by DSP at 819.2 KHz system clock (At this time, only RMS calculation is supported, users can select RMS channel through DSP_CTRL6 register.) 9: 16 sampling points per cycle by DSP at 409.6 KHz system clock (At this time, only RMS calculation is supported, users can select RMS channel through DSP_CTRL6 register.) Others: the same as mode 0
3	-	-	0	Reserved
2	ADCUEN	R/W	0	To enable the voltage channel (including ADC and DSP).
1	ADCIBEN	R/W	0	To enable the current channel B (including ADC and DSP).
0	ADCIAEN	R/W	0	To enable the current channel A (including ADC and DSP).

2.4.2 DSP_CTRL1 Register

Table23. Metering Control Register 2 (0x03, DSP_CTRL1)

0x03, R/W, Metering Control Register 2, DSP_CTRL1				
Bit		R/W	Default Value	Description
31	BW_COMP	R/W	0	Automatic gain compensation for filter. By default, this function was enabled. This bit does not influence DC metering. It will automatic turn off during the DC metering. 0: enable 1: disable
30:22	Reserved		0	The bit must hold its default value for proper operation.
23	EGY_CLK_SEL	R/W	0	To select the energy accumulator CLK. It needs the stable time around 107 μ s when CLK switch over. Please disable CF before it is stable. 0: 204.8 KHz 1: 32.768 KHz
22	LCF_ACC	R/W	0	0: disable To write "0" into the bit31 of the DSP_CTRL0 the accumulating cycle of energy accumulator 3, 4, 5, 6, 7, and 8 is 20ms. To write "1" into the bit31 of the DSP_CTRL0, the accumulating cycle of energy accumulator 3, 4, 5, 6, 7, and 8 is 40 ms. 1: enable To write "0" into the bit31 of the DSP_CTRL0, the accumulating cycle of energy accumulator 3, 4, and 5 is 10 ms. Energy accumulator 6, 7, and 8 not accumulate. To write "1" into the bit31 of the DSP_CTRL0, the accumulating cycle of energy accumulator 3, 4, and 5 is 20 ms. Energy accumulator 6, 7, and 8 not accumulate.
21	PGA_U	R/W	0	Voltage channel digital PGA: 0: X1 1: X4
20	PHSI_SEL	R/W	0	To select the input source for current zero-

0x03, R/W, Metering Control Register 2, DSP_CTRL1				
Bit		R/W	Default Value	Description
				crossing. 0: current channel IA 1: current channel IB
19:18	SIGN_SEL	R/W	0	To select the detect method of zero-crossing: 0: negative direction (it indicates the signal changing from positive to negative is occurring a zero-crossing event) 1: positive direction (it indicates the signal changing from negative to positive is occurring a zero-crossing event) 2: positive and negative direction 3: disable the zero-crossing detection function
17	AUTO_BAUD	R/W	0	Actively power accumulating data uploads, the upload interface can pass SYS_IOCFGX P0/ P1/ P2/ P3/ P4/ P5/ P6 pin configuration as the actively data uploads. Can use communicating methods to configure UART baud rate. 0: When UART communicates, baud rate is the same as last time serial communication. The baud rate when SPI communication is 4800. 1: When UART communicates, baud rate is as much again of last time serial communication. The baud rate when SPI communication is 9600.
16	AUTO_TX_EN	R/W	0	To enable the active power accumulating data uploads. 0: disable 1: enable
15	EGY_LC_EN	R/W	0	To enable the low-speed energy accumulator and CF counter. The accumulating speed of low-speed energy accumulator is 50 Hz. 0: disable 1: enable.
14	CF2_INV	R/W	0	To control the CF2 polarity. 0: original polarity 1: reverse polarity

0x03, R/W, Metering Control Register 2, DSP_CTRL1				
Bit		R/W	Default Value	Description
13	CF2_EN	R/W	0	To Enable the CF2 output. 0: disable 1: enable.
12	CF2_SEL	R/W	0	To select the input source of CF2. 0: from the energy accumulator 1 1: from the energy accumulator 2
11	Reserved		0	The bit must hold its default value for proper operation.
10	CF1_INV	R/W	0	To control CF1 polarity. 0: original polarity 1: reverse polarity
9	CF1_EN	R/W	0	To enable CF1 output. 0: disable CF1 output 1: enable CF1 output
8	CF1_SEL	R/W	0	To select the input source of CF1. 0: from the energy accumulator 1 1: from the energy accumulator 2
7	CALCEN2	R/W	0	To enable the energy accumulator 2 and CF2 counter. The accumulating speed of energy accumulator 2 is 204.8 KHz. 0: disable 1: enable.
6	CALCEN1	R/W	0	To enable the energy accumulator 1 and CF1 counter. The accumulating speed of energy accumulator 1 is 204.8 KHz. 0: disable 1: enable
5:4	CF_PULSE	R/W	0	To select the CF pulse width 0: 80 ms 1: 40 ms 2: 20 ms 3: 10 ms
3:2	CF_FAST_EN	R/W	0	CF pulse speed up output. 0: Normal mode 1: 4x faster

0x03, R/W, Metering Control Register 2, DSP_CTRL1				
Bit		R/W	Default Value	Description
				2: 8x faster 3: 16x faster
1	PWR_CRP_EN	R/W	0	To determine the power of power-creep. The power-creep determination uses continuous 3 average and threshold compare. If lower the threshold, then here will be the power-creep status. 0: disable the power-creep detection 1: enable the power-creep detection
0	CRP_EN	R/W	0	To enable the High-speed energy accumulator. 0: disable the power-creep detection 1: enable the power-creep detection

2.4.3 DSP_CTRL2 Register

Table24. Metering Control Register 2 (0x04, DSP_CTRL2)

0x04, R/W, Metering Control Register 2, DSP_CTRL2				
Bit		R/W	Default Value	Description
31:30	INMODE4	R/W	0	The energy accumulator 4 accumulating mode. 0: power accumulation 1: current RMS accumulation 2: constant accumulation 3: configurable fundamental-wave channel accumulation
29	A_SEL4	R/W	0	To enable the energy accumulator 4, channel A accumulating. 0: disable 1: enable
28	B_SEL4	R/W	0	To enable the energy accumulator 4, channel B accumulating. 0: disable 1: enable
27:26	TYPE_SEL4	R/W	0	The energy accumulator 4, multiple channel accumulating mode choice. When power accumulating,

0x04, R/W, Metering Control Register 2, DSP_CTRL2				
Bit		R/W	Default Value	Description
				0, 3: active power accumulation 1: reactive power accumulation 2: apparent power accumulation When RMS accumulating, high bit zero represents accumulating sum; High bit one represents accumulating difference.
25:24	PROCMODE4	R/W	0	For each signal type choices which feed into the energy accumulator 4. 0: the positive value of the energy accumulator adding 1: the negative value of the energy accumulator adding (Here the actual accumulating value is the positive which exchanged from the original value.) 2: the original value of the energy accumulator adding 3: the absolute value of the energy accumulator adding
23:22	INMODE3	R/W	0	The energy accumulator 3 accumulation mode 0: power accumulation 1: current RMS accumulation 2: constant accumulation 3: configurable the fundamental wave channel accumulation
21	A_SEL3	R/W	0	To enable the energy accumulator 3, channel A accumulating. 0: disable; 1: enable
20	B_SEL3	R/W	0	To enable the energy accumulator 3, channel B accumulating. 0: disable 1: enable
19:18	TYPE_SEL3	R/W	0	The energy accumulator 3, multiple channel accumulating mode choice. When power accumulating, 0, 3: active power accumulation

0x04, R/W, Metering Control Register 2, DSP_CTRL2				
Bit		R/W	Default Value	Description
				1: reactive power accumulation 2: apparent power accumulation When RMS accumulating, High bit zero represents accumulating sum; high bit one represents accumulating difference.
17:16	PROCMODE3	R/W	0	For each signal type choices which feed into the energy accumulator 3. 0: the positive value of the energy accumulator adding 1: the negative value of the energy accumulator adding (Here the actual accumulating value is the positive which exchanged from the original value.) 2: the original value of the energy accumulator adding 3: the absolute value of the energy accumulator adding
15:14	INMODE2	R/W	0	The energy accumulator 2 accumulating mode. 0: power accumulation 1: current RMS accumulation 2: constant accumulation 3: configurable the fundamental wave channel accumulation
13	A_SEL2	R/W	0	To enable the energy accumulator 2, channel A accumulating. 0: disable 1: enable
12	B_SEL2	R/W	0	To enable the energy accumulator 2, channel B accumulating. 0: disable 1: enable
11:10	TYPE_SEL2	R/W		The energy accumulator 2, multiple channel accumulating mode choice. When power accumulating, 0, 3: active power accumulation 1: reactive power accumulation

0x04, R/W, Metering Control Register 2, DSP_CTRL2				
Bit		R/W	Default Value	Description
				2: apparent power accumulation When RMS accumulating, High bit zero represents accumulating sum; high bit one represents accumulating difference.
9:8	PROCMODE2	R/W	0	For each signal type choices which feed into the energy accumulator 2. 0: the positive value of the energy accumulator adding 1: the negative value of the energy accumulator adding (Here the actual accumulating value is the positive which exchanged from the original value.) 2: the original value of the energy accumulator adding 3: the absolute value of the energy accumulator adding
7:6	INMODE1	R/W	0	The energy accumulator 1 accumulating mode. 0: power accumulation 1: current RMS accumulation 2: constant accumulation 3: configurable the fundamental wave channel accumulation
5	A_SEL1	R/W	0	To enable the energy accumulator 1, channel A accumulating. 0: disable 1: enable
4	B_SEL1	R/W	0	To enable the energy accumulator 1, channel B accumulating. 0: disable 1: enable
3:2	TYPE_SEL1	R/W	0	Multiple channel accumulating mode choice. When power accumulating, 0, 3: active power accumulation 1: reactive power accumulation 2: apparent power accumulation When RMS accumulating,

0x04, R/W, Metering Control Register 2, DSP_CTRL2				
Bit		R/W	Default Value	Description
				High bit zero represents accumulating sum; high bit one represents accumulating difference.
1:0	PROCMODE1	R/W	0	For each signal type choices which feed into the energy accumulator 1. 0: the positive value of the energy accumulator adding 1: the negative value of the energy accumulator adding (Here the actual accumulating value is the positive which exchanged from the original value.) 2: the original value of the energy accumulator adding 3: the absolute value of the energy accumulator adding

2.4.4 DSP_CTRL3 Register

Table25. Metering Control Register 3 (0x05, DSP_CTRL3)

0x05, R/W, Metering Control Register 3, DSP_CTRL3				
Bit		R/W	Default Value	Description
31:30	INMODE8	R/W	0	The energy accumulator 8 accumulating mode. 0: power accumulation 1: current RMS accumulation 2: constant accumulation 3: configurable the fundamental wave channel accumulation
29	A_SEL8	R/W	0	To enable the energy accumulator 8, channel A accumulating. 0: disable 1: enable
28	B_SEL8	R/W	0	To enable the energy accumulator 8, channel B accumulating. 0: disable 1: enable
27:26	TYPE_SE	R/W	0	The energy accumulator 8, multiple channel

0x05, R/W, Metering Control Register 3, DSP_CTRL3				
Bit		R/W	Default Value	Description
	L8			accumulating mode choice. When power accumulating, 0, 3: active power accumulation 1: reactive power accumulation 2: apparent power accumulation When RMS accumulating, High bit zero represents accumulating sum; high bit one represents accumulating difference.
25:24	PROCMODE8	R/W	0	For each signal type choices which feed into the energy accumulator 8. 0: the positive value of the energy accumulator adding 1: the negative value of the energy accumulator adding (Here the actual accumulating value is the positive which exchanged from the original value.) 2: the original value of the energy accumulator adding 3: the absolute value of the energy accumulator adding
23:22	INMODE7	R/W	0	The energy accumulator 7 accumulating mode 0: power accumulation 1: current RMS accumulation 2: constant accumulation 3: configurable the fundamental wave channel accumulation
21	A_SEL7	R/W	0	To enable the energy accumulator 7, channel A accumulating 0: disable 1: enable
20	B_SEL7	R/W	0	To enable the energy accumulator 7, channel B accumulating 0: disable 1: enable
19:18	TYPE_SEL7	R/W	0	The energy accumulator 7, multiple channel accumulating mode choice.

0x05, R/W, Metering Control Register 3, DSP_CTRL3				
Bit		R/W	Default Value	Description
				When power accumulating, 0, 3: active power accumulation 1: reactive power accumulation 2: apparent power accumulation When RMS accumulating, High bit zero represents accumulating sum; high bit one represents accumulating difference.
17:16	PROCMODE7	R/W	0	For each signal type choices which feed into the energy accumulator 7. 0: the positive value of the energy accumulator adding 1: the negative value of the energy accumulator adding (Here the actual accumulating value is the positive which exchanged from the original value.) 2: the original value of the energy accumulator adding 3: the absolute value of the energy accumulator adding
15:14	INMODE6	R/W	0	The energy accumulator 6 accumulating mode. 0: power accumulation 1: current RMS accumulation 2: constant accumulation 3: configurable the fundamental wave channel accumulation
13	A_SEL6	R/W	0	To enable the energy accumulator 6, channel A accumulating. 0: disable 1: enable
12	B_SEL6	R/W	0	To enable the energy accumulator 6, channel B accumulating. 0: disable 1: enable
11:10	TYPE_SEL6	R/W		The energy accumulator 6, multiple channel accumulating mode choice. When power accumulating,

0x05, R/W, Metering Control Register 3, DSP_CTRL3				
Bit		R/W	Default Value	Description
				0, 3: active power accumulation 1: reactive power accumulation 2: apparent power accumulation When RMS accumulating, High bit zero represents accumulating sum; high bit one represents accumulating difference.
9:8	PROCMODE6	R/W	0	For each signal type choices which feed into the energy accumulator 6. 0: the positive value of the energy accumulator adding 1: the negative value of the energy accumulator adding (Here the actual accumulating value is the positive which exchanged from the original value.) 2: the original value of the energy accumulator adding 3: the absolute value of the energy accumulator adding
7:6	INMODE5	R/W	0	The energy accumulator 5 accumulating mode. 0: power accumulation 1: current RMS accumulation 2: constant accumulation 3: configurable the fundamental wave channel accumulation
5	A_SEL5	R/W	0	To enable the energy accumulator 5, channel A accumulating. 0: disable 1: enable
4	B_SEL5	R/W	0	To enable the energy accumulator 5, channel B accumulating. 0: disable 1: enable
3:2	TYPE_SEL5	R/W	0	The energy accumulator 5, multiple channel accumulating mode choice. When power accumulating, 0, 3: active power accumulation

0x05, R/W, Metering Control Register 3, DSP_CTRL3				
Bit		R/W	Default Value	Description
				1: reactive power accumulation 2: apparent power accumulation When RMS accumulating, High bit zero represents accumulating sum; high bit one represents accumulating difference.
1:0	PROCMODE5	R/W	0	For each signal type choices which feed into the energy accumulator 5. 0: the positive value of the energy accumulator adding 1: the negative value of the energy accumulator adding (Here the actual accumulating value is the positive which exchanged from the original value.) 2: the original value of the energy accumulator adding 3: the absolute value of the energy accumulator adding

2.4.5 DSP_CTRL4 Register

Table26. Metering Control Register 4 (0x06, DSP_CTRL4)

0x06, R/W, Metering Control Register 4, DSP_CTRL4				
Bit		R/W	Default Value	Description
31:30	IPERIOD	R/W	0	To select the detection time of over-current or under-current. When the number of sampling points of over-current or under-current in the sampling points during the half-cycle is greater than or equal to the ITH value, it will be considered as the effective half-cycle. If the number of consecutive effective half-cycle reaches the value set by IPERIOD, it will be considered as this event happened. 0: half cycle 1: 1 cycle 2: 2 cycles 3: 4 cycles

0x06, R/W, Metering Control Register 4, DSP_CTRL4				
Bit		R/W	Default Value	Description
29:24	ITH	R/W	0	To determine the threshold of half-cycle is effective half-cycle. 0: 1 sampling point 1: 2 sampling points ... 63: 64 sampling points
23:22	UPERIOD	R/W	0	The same as IPERIOD configurable conditions. 0: half cycle 1: 1 cycle 2: 2 cycles 3: 4 cycles
21:16	UTH	R/W	0	The same as ITH configurable conditions. 0: 1 sampling point 1: 2 sampling points ... 63: 64 sampling points
15:10	Reserved			These bits must hold its default value for proper operation.
9	IBLCS EL	R/W	0	IB under- current test source. 0: no pass IB wave data of high pass filter 1: pass IB wave data of high pass filter
8	IBOCS EL	R/W	0	IB: over-current test source. 0: no pass IB wave data of high pass filter 1: pass IB wave data of high pass filter
7	IALCS EL	R/W	0	IA under-current test source. 0: no pass IA wave data of high pass filter 1: pass IA wave data of high pass filter
6	IAOCS EL	R/W	0	IA over-current test source. 0: no pass IA wave data of high pass filter 1: pass IA wave data of high pass filter
5	ULVSEL	R/W	0	Channel U under-voltage test source. 0: no pass channel U wave data of high pass filter 1: pass channel U wave data of high pass filter
4	UOVSEL	R/W	0	Channel U over-voltage test source. 0: no pass channel U wave data of high pass filter

0x06, R/W, Metering Control Register 4, DSP_CTRL4				
Bit		R/W	Default Value	Description
				1: pass channel U wave data of high pass filter
3	Reserved		0	The bit must hold its default value for proper operation.
2	FDIBEN	R/W	0	To enable the fast detection for IB. 0: disable IB over or under current test 1: enable IB over or under current test
1	FDIAEN	R/W	0	To enable the fast detection for IA. 0: disable IA over or under current test 1: enable IA over or under current test
0	FDUEN	R/W	0	To enable the fast detection. 0: disable channel U over or under voltage test 1: enable channel U over or under voltage test

2.4.6 DSP_CTRL5 Register

Table27. Metering Control Register 5 (0x07, DSP_CTRL5)

0x07, R/W, Metering Control Register 5, DSP_CTRL5				
Bit		R/W	Default Value	Description
31	WAVE_ADDR_CLR	R/W	0	Reset reading the address of waveform storage, write 1 to reset.
30:29	WAVE_MDSP_MODE	R/W	0	The operating mode of waveform storage: 0: storage by manual, full then stop. This time is the single storage. 1: storage by manual, trigger or manual stop. This time is the cyclic storage. 2: storage by trigger, full then stop. This time is the single storage. 3: disable
28	WAVE_MEM_EN	R/W	0	Waveform storage to trigger manual switch: write 1 = enable, write 0 = disable 0: disable 1: enable

0x07, R/W, Metering Control Register 5, DSP_CTRL5				
Bit		R/W	Default Value	Description
27	U_DIP_TRIG	R/W	0	Event trigger for the voltage dip. 0: disable 1: enable
26	U_SWELL_TRIG	R/W	0	Event trigger for the voltage swell. 0: disable 1: enable
25	IB_LC_TRIG	R/W	0	Event trigger for the IB under-current. 0: disable 1: enable
24	IB_OC_TRIG	R/W	0	Event trigger for the IB over-current. 0: disable 1: enable
23	IA_LC_TRIG	R/W	0	Event trigger for the IA under-current. 0: disable 1: enable
22	IA_OC_TRIG	R/W	0	Event trigger for the IA over-current. 0: disable 1: enable
21	U_LV_TRIG	R/W	0	Event trigger for Under-voltage. 0: disable 1: enable
20	U_OV_TRIG	R/W	0	Event trigger for Over-voltage. 0: disable 1: enable
19:16	WAVE_LENGTH	R/W	0	To select output waveform length of DMA channel. 0: 1 cycle 1: 2 cycles 2: 3 cycles 15: 16 cycles
15	Reserved	-	-	The bit must hold its default value for proper operation.

0x07, R/W, Metering Control Register 5, DSP_CTRL5				
Bit		R/W	Default Value	Description
14	WAVE_U_HPF_SEL	R/W	0	Voltage waveform whether pass high-pass filter choice: 0: no pass high-pass filter 1: pass high-pass filter
13	WAVE_IA_HPF_SEL	R/W	0	Current IA waveform whether pass high-pass filter choice: 0: no pass high-pass filter 1: pass high-pass filter
12	WAVE_IB_HPF_SEL	R/W	0	Current IB waveform whether pass high-pass filter choice: 0: no pass high-pass filter 1: pass high-pass filter
11	Reserved	-	-	The bit must hold its default value for proper operation.
10	WAVE_U_SEL	R/W	0	To enable the waveform storage and DMA of channel U. The bit decides whether storage or transmit data of channel U: 0: no 1: yes
9	WAVE_IA_SEL	R/W	0	To Enable the waveform storage and DMA of channel IA. The bit decides whether storage or transmit data of channel IA: 0: no 1: yes
8	WAVE_IB_SEL	R/W	0	To enable the waveform storage and DMA of channel IB. The bit decides whether storage or transmit data of channel IB (If waveform storage and configure bit 8, bit 9, and bit 10 enable at the same time, the bit becomes invalid): 0: no 1: yes
7	SP_CHECK	R/W	0	DMA mode parity check choice: 0: odd parity 1: even parity

0x07, R/W, Metering Control Register 5, DSP_CTRL5				
Bit		R/W	Default Value	Description
6	SPI_POL	R/W	0	DMA mode polarity choice: 0: negative 1: positive
5	SPI_PHA	R/W	0	DMA mode phase choice: 0: negative 1: positive
4:3	DMA_MANUAL CTRL	R/W	0	DMA channel choice: 0: disable 1: enable by manual 2: stop by manual 3: reserved
2:0	DMA_MODE	R/W	0	DMA channel operating mode: 0: transmit starting by manual, until maximum cycle then stops. 1: transmit starting by manual, trigger or by manual stop. 2: trigger starting, stop by manual. 3: trigger starting, until maximum cycle then stops. 4~7: transmit by manual, stop by manual. Before enabling DMA transmission, at least one channel of waveform storage and upload must be opened.

2.4.7 DSP_CTRL6 Register

Table28. Metering Control Registers (0x80, DSP_CTRL6)

0x80, R/W, Metering Control Registers, DSP_CTRL6				
Bit		R/W	Default Value	Description
31	WAVE_POINT_ON	R/W	0	Waveform upload and storage sample rate reduction switch 0: Disable; 1: Enable; When disable, the waveform upload and

0x80, R/W, Metering Control Registers, DSP_CTRL6				
Bit		R/W	Default Value	Description
				storage sample rate is same as the measurement storage sample rate.
30:29	WAVE_POINT	R/W	0	The basic sample rate is determined by the sample rate of measurement 0: X 1 (128, 64, 32 sample rate can be used) 1: X 1/2 (128, 64 sample rate available) 2: X 1/4 (only 128 sample rate can be used) 3: Same as configuration 0
28	DIDT_IA_ON	R/W	0	Roche coil processing switch for IA current channel. 0: Not enabled; 1: Enable; Cannot be turned on simultaneously with the fundamental accuracy improvement switch. If it is turned on simultaneously, the default Rogowski coil is valid, and the fundamental accuracy improvement is invalid. The opening of the Roche coil is not supported when DSP_MODE=8, 9.
27	DIDT_IB_ON	R/W	0	Roche coil processing switch for IB current channel. 0: Not enabled; 1: Enable; Cannot be turned on simultaneously with the fundamental accuracy improvement switch. If it is turned on simultaneously, the default Rogowski coil is valid, and the fundamental accuracy improvement is invalid. The opening of the Roche coil is not supported when DSP_MODE=8, 9.
26	ZERO_EN_TH	R/W	0	Voltage zero crossing detection threshold switch. 0: disable; 1: enable;

0x80, R/W, Metering Control Registers, DSP_CTRL6				
Bit		R/W	Default Value	Description
25	FUND_CALI_ON	R/W	0	Fundamental independent correction switch 0: Disable; 1: Enable; When the fundamental independent calibration switch is turned on, the fundamental correction register will be calibrated using the register related to address 0x81-0x8e. Otherwise, the register related to address 0x25-0x32 will be used for calibration.
24	FUND_PREC_ON		0	Fundamental wave improves measurement accuracy switch 0: Off, with the same accuracy as before 1: Enable, improve the accuracy of fundamental wave measurement It is not possible to turn on the sampling switch of the Roche coil at the same time. If the fundamental data is turned on at the same time, there will be an error. When the center frequency is 60Hz, an additional Bit[8] switch needs to be turned on.
23:21	Reserved	-	-	The bit must hold its default value for proper operation.
20	SEL_ON	R/W	0	At low speed system clock (819.2/409.6 KHz), switch different paths for calculating the RMS value 0: Off. Enable RMS value calculation for IA and IB channels. 1: Open, related RMS_SEL
19:18	RMS_SEL	R/W	0	When SEL_ON is turned on, select the RMS value calculation path 0: Enable RMS value calculation for U and IA channel 1: Same as configuration 0

0x80, R/W, Metering Control Registers, DSP_CTRL6				
Bit		R/W	Default Value	Description
				2: Enable RMS value calculation for IA and IB channels 3: Same as configuration 2
17	FRQ_ANA_ON	R/W	0	Frequency measurement mode switch 0: Off. The original digital frequency measurement mode will be used. 1: On. The analog frequency measurement mode will be used.
16	FRQ_UNIT_ON	R/W	0	Average period cycle switch for digital frequency measurement mode 0: Still managed by FRQ_SEL 1: Managed By FRQ_UNIT_SEL This switch only applies to the selection of digital measurement frequency average period, and has no effect on the selection of analog measurement frequency average period.
15:12	FRQ_UNIT_SEL	R/W	0	Digital/Analog Measurement Frequency Average Period Selection 0: 1 cycle 1: 2 cycles ... 15: 16 cycles
11	ZERO_EN_TH_I	R/W	0	Enable Current zero crossing detection threshold, shared by IA/IB. 0: Disable; 1: Enable;
10	RCH_OUT_EN	R/W	0	Internal RCH clock output enable through Px pin 0: Disable 1: Enable
9	RCL_OUT_EN	R/W	0	Internal RCL clock output enable through Px pin 0: Disable 1: Enable

0x80, R/W, Metering Control Registers, DSP_CTRL6				
Bit		R/W	Default Value	Description
8	FREQ_CHANGE	R/W	0	0: 50Hz center frequency 1: 60Hz center frequency When the center frequency is 60Hz, opening this switch together with the fundamental accuracy improvement switch can improve the fundamental measurement accuracy of 60Hz
7:0	Reserved	-	-	The bit must hold its default value for proper operation.

2.4.8 DIP_SWELL_CTRL Register

Table29. Voltage surge control register (0x8f, DIP_SWELL_CTRL)

0x8f, R/W, Voltage surge control register, DIP_SWELL_CTRL				
Bit		R/W	Default Value	Description
31	DIP_END	R/C	0	End of voltage drop event interrupt Read 0: The end of the voltage drop event did not occur; Read 1: The end of the voltage drop event has occurred; Write 0: no effects Write 1: clear the bit
30	SWELL_END	R/C	0	End of voltage surge event interrupt Read 0: The end of the voltage surge event did not occur; Read 1: The end of the voltage surge event has occurred; Write 0: no effects Write 1: clear the bit

0x8f, R/W, Voltage surge control register, DIP_SWELL_CTRL				
Bit		R/W	Default Value	Description
29	DIP_END_EN	R/W	0	End of voltage drop event interrupt enable 0: Disable 1: Enable
28	SWELL_END_EN	R/W	0	End of voltage surge event interrupt enable 0: Disable 1: Enable
27:12	DIP_SWELL_UNIT	R/W	0	Time unit selection for voltage surge/drop judgment, with half wave as the minimum granularity 0: Half wave judgment 1: Whole cycle judgment The maximum value can reach 65536 half waves
11:0	Reserved	-	-	The bit must hold its default value for proper operation.

2.5 Metering Data Register

When RSTN pin reset, RX reset, or global software reset occurs, all metering control registers will be reset to the default value.

2.5.1 DC Component Register

Table30. DC Component Register

Address	Register	R/W	Data Format	Description	
0x22	DSP_DAT_DCU	R	32-bit Complement Code	DC value of voltage channel.	By default, the updating time is 40 ms; stable time is 120 ms.
0x23	DSP_DAT_DCI	R	32-bit Complement Code	DC value of current channel A.	

Address	Register	R/W	Data Format	Description
0x24	DSP_DAT_DCIB	R	32-bit Complement Code	DC value of Current channel B.

2.5.2 RMS Register

Table31. Voltage/ Current/ Measurement Signal (M) RMS Register

Address	Register	R/W	Data Format	Description
0x0E	DSP_DAT_RMS0U	R	32-bit Complement Code	Instantaneous RMS of voltage.
0x0F	DSP_DAT_RMS0IA	R	32-bit Complement Code	Instantaneous RMS of current A.
0x10	DSP_DAT_RMS0IB	R	32-bit Complement Code	Instantaneous RMS of current B.
0x19	DSP_DAT_RMS1U	R	32-bit Complement Code	Average RMS of voltage.
0x1A	DSP_DAT_RMS1IA	R	32-bit Complement Code	Average RMS of Current A.
0x1B	DSP_DAT_RMS1IB	R	32-bit Complement Code	Average RMS of Current B.
0x1E	DSP_DAT_RMSU_AVG	R	32-bit Complement Code	Average RMS of Voltage for 10 or 12 cycles (chose by line frequency.)
0x1F	DSP_DAT_RMSIA_AVG	R	32-bit Complement Code	Average RMS of Current IA for 10 or 12 cycles (chose by line frequency.)

Address	Register	R/W	Data Format	Description
0x20	DSP_DAT_RMSIB_AVG	R	32-bit Complement Code	Average RMS of Current IB for 10 or 12 cycles (chosed by line frequency.)

2.5.3 Active/ Reactive Power Register

Table32. Active/ Reactive Power Register

Address	Register	R/W	Data Format	Description
0x08	DSP_DAT_PA	R	32-bit Complement Code	Instantaneous Active Power of channel A.
0x09	DSP_DAT_QA	R	32-bit Complement Code	Instantaneous Reactive Power of channel A.
0x0A	DSP_DAT_SA	R	32-bit Complement Code	Instantaneous Apparent Power of channel A.
0x0B	DSP_DAT_PB	R	32-bit Complement Code	Instantaneous Active Power of channel B.
0x0C	DSP_DAT_QB	R	32-bit Complement Code	Instantaneous Reactive Power of channel B.
0x0D	DSP_DAT_SB	R	32-bit Complement Code	Instantaneous Apparent Power of channel B.
0x13	DSP_DAT_PA1	R	32-bit Complement Code	Average Active power of Channel A.
0x14	DSP_DAT_QA1	R	32-bit Complement Code	Average Reactive power of Channel A.
0x15	DSP_DAT_SA1	R	32-bit Complement Code	Average Apparent Power of Channel A.

By default, the updating time is 20 ms; stable time is 60 ms.

By default, the updating time is 80 ms; stable time is 240 ms.

Address	Register	R/W	Data Format	Description
0x16	DSP_DAT_PB1	R	32-bit Complement Code	Average Active power of Channel B.
0x17	DSP_DAT_QB1	R	32-bit Complement Code	Average Reactive power of Channel B.
0x18	DSP_DAT_SB1	R	32-bit Complement Code	Average Apparent Power of Channel B.

2.5.4 Fundamental Wave Channel Register

Table33. Fundamental Wave Channel Instantaneous Register

Address	Register	R/W	Data Format	Description
0x11	DSP_DAT_CH1	R	32-bit Complement Code	Instantaneous value of Fundamental wave of Channel 1.
0x12	DSP_DAT_CH2	R	32-bit Complement Code	Instantaneous value of Fundamental wave of Channel 2.

Table34. Fundamental Wave Channel Average Register

Address	Register	R/W	Data Format	Description
0x1C	DSP_DAT_CH1_AVG	R	32-bit Complement Code	Average value of Fundamental wave of Channel 1.
0x1D	DSP_DAT_CH2_AVG	R	32-bit Complement Code	Average value of Fundamental wave of Channel 2.

2.5.5 Line Frequency Register

Table35. Line Frequency Register (0x21, DSP_DAT_FRQ)

Address	Register	R/W	Data Format	Description
0x21	DSP_DAT_FRQ	R	32-bit Complement Code	Line frequency is related to FRQ_SEL. By default, the updating time is 320 ms; stable time is 640 ms.

2.6 Energy Accumulator Register

Table36. Energy Accumulator Register

Address	Register	R/W	Data Format	Description
0x39	EGY_PROCTH	R	32-bit Unsigned	Anti-creep threshold for energy accumulator. When the accumulated value of the anti-creep energy accumulator over this threshold and the accumulated value of the high-speed energy accumulator under this threshold, the accumulated value of the high-speed energy accumulator will be cleared.
0x3A	EGY_PWRTH	R/W	32-bit Unsigned	Accumulation threshold for energy accumulator. Due to the energy accumulator was 46bit, the accumulated value of the high-speed energy accumulator equals to this value*16384; the accumulated value of the low-speed energy accumulator equals to this value*4.
0x3B	EGY_CONST1	R/W	32-bit Unsigned	Energy accumulator 1 accumulating constant. Due to the format of the register value data being a 32-bit unsigned number, when the highest bit is 1, the data is very large, so it is not recommended to configure the highest bit to 1.
0x3C	EGY_OUT1L	R/W	32-bit Unsigned	Energy accumulator 1 accumulating low bit.
0x3D	EGY_OUT1H	R/W	32-bit Unsigned	Energy accumulator 1 accumulating high bit Low 14bit effective.

Address	Register	R/W	Data Format	Description
0x3E	EGY_CFCNT1	R/W	32-bit Unsigned	Energy accumulator 1 pulse counter. Every time the high-speed energy accumulator overflows twice, the count value increases by 1.
0x3F	EGY_CONST2	R	32-bit Unsigned	Energy accumulator 2 accumulating constant. Due to the format of the register value data being a 32-bit unsigned number, when the highest bit is 1, the data is very large, so it is not recommended to configure the highest bit to 1.
0x40	EGY_OUT2L	R/W	32-bit Unsigned	Energy accumulator 2 accumulating low bit.
0x41	EGY_OUT2H	R/W	32-bit Unsigned	Energy accumulator 2 accumulating high bit Low 14bit effective.
0x42	EGY_CFCNT2	R/W	32-bit Unsigned	Energy accumulator 2 pulse counter. Every time the high-speed energy accumulator overflows twice, the count value increases by 1.
0x43	EGY_CONST3	R	32-bit Unsigned	Energy accumulator 3 accumulating constant. Due to the format of the register value data being a 32-bit unsigned number, when the highest bit is 1, the data is very large, so it is not recommended to configure the highest bit to 1.
0x44	EGY_OUT3	R/W	32-bit Unsigned	Energy accumulator 3 accumulating value.
0x45	EGY_CFCNT3	R/W	32-bit Unsigned	Energy accumulator 3 pulse counter. Every time the low-speed energy accumulator overflows, the count value increases by 1.

Address	Register	R/W	Data Format	Description
0x46	EGY_CONST4	R	32-bit Unsigned	Energy accumulator 4 accumulating constant. Due to the format of the register value data being a 32-bit unsigned number, when the highest bit is 1, the data is very large, so it is not recommended to configure the highest bit to 1.
0x47	EGY_OUT4	R/W	32-bit Unsigned	Energy accumulator 4 accumulating value.
0x48	EGY_CFCNT4	R/W	32-bit Unsigned	Energy accumulator 4 pulse counter. Every time the low-speed energy accumulator overflows, the count value increases by 1.
0x49	EGY_CONST5	R	32-bit Unsigned	Energy accumulator 5 accumulating constant. Due to the format of the register value data being a 32-bit unsigned number, when the highest bit is 1, the data is very large, so it is not recommended to configure the highest bit to 1.
0x4A	EGY_OUT5	R/W	32-bit Unsigned	Energy accumulator 5 accumulating value.
0x4B	EGY_CFCNT5	R/W	32-bit Unsigned	Energy accumulator 5 pulse counter. Every time the low-speed energy accumulator overflows, the count value increases by 1.
0x4C	EGY_CONST6	R	32-bit Unsigned	Energy accumulator 6 accumulating constant. Due to the format of the register value data being a 32-bit unsigned number, when the highest bit is 1, the data is very large, so it is not recommended to configure the highest bit to 1.
0x4D	EGY_OUT6	R/W	32-bit Unsigned	Energy accumulator 6 accumulating value.

Address	Register	R/W	Data Format	Description
0x4E	EGY_CFCNT6	R/W	32-bit Unsigned	Energy accumulator 6 pulse counter. Every time the low-speed energy accumulator overflows, the count value increases by 1.
0x4F	EGY_CONST7	R	32-bit Unsigned	Energy accumulator 7 accumulating constant. Due to the format of the register value data being a 32-bit unsigned number, when the highest bit is 1, the data is very large, so it is not recommended to configure the highest bit to 1.
0x50	EGY_OUT7	R/W	32-bit Unsigned	Energy accumulator 7 accumulating value.
0x51	EGY_CFCNT7	R/W	32-bit Unsigned	Energy accumulator 7 pulse counter. Every time the low-speed energy accumulator overflows, the count value increases by 1.
0x52	EGY_CONST8	R	32-bit Unsigned	Energy accumulator 8 accumulating constant. Due to the format of the register value data being a 32-bit unsigned number, when the highest bit is 1, the data is very large, so it is not recommended to configure the highest bit to 1.
0x53	EGY_OUT8	R/W	32-bit Unsigned	Energy accumulator 8 accumulating value.
0x54	EGY_CFCNT8	R/W	32-bit Unsigned	Energy accumulator 8 pulse counter. Every time the low-speed energy accumulator overflows, the count value increases by 1.

2.7 Phase Measurement Register

Table37. Phase Measurement Register

Address	Register	R/W	Data Format	Description
0x61	DSP_PHS_STT	R/W	32-bit Unsigned	To control the phase measurement. Enable phase measurement once

Address	Register	R/W	Data Format	Description
				for writing operation.
0x62	DSP_PHS_U	R	32-bit Unsigned	Voltage Phase Value.
0x63	DSP_PHS_UN	R	32-bit Unsigned	The waveform data before voltage zero-crossing.
0x64	DSP_PHS_UP	R	32-bit Unsigned	The waveform data after voltage zero-crossing.
0x65	DSP_PHS_I	R	32-bit Unsigned	Current Phase Value.
0x66	DSP_PHS_IN	R	32-bit Unsigned	The waveform data before current zero-crossing.
0x67	DSP_PHS_IP	R	32-bit Unsigned	The waveform data after current zero-crossing.

2.8 Power-creep Threshold Register

Table38. Power-creep Threshold Register

Address	Register	R/W	Data Format	Description
0x55	DSP_OV_THL	R/W	32-bit Complement Code	To set the lower threshold for the power creep detection for instantaneous active power/ reactive power/ apparent power of channel A and B.
0x56	DSP_OV_THH	R/W	32-bit Complement Code	To set the upper threshold for the power creep detection for instantaneous active power/ reactive power/ apparent power of channel A and B.

2.9 Voltage Swell or Dip Threshold Register

Table39. Voltage Swell or Dip Threshold Register

Address	Register	R/W	Data Format	Description
0x57	DSP_SWELL_THL	R/W	32-bit Complement Code	To set the lower threshold for the voltage swell.
0x58	DSP_SWELL_THH	R/W	32-bit Complement Code	To set the upper threshold for the voltage swell.

Address	Register	R/W	Data Format	Description
0x59	DSP_DIP_THL	R/W	32-bit Complement Code	To set the lower threshold for the voltage dip.
0x5A	DSP_DIP_THH	R/W	32-bit Complement Code	To set the upper threshold for the voltage dip.
0x6A	DAT_SWELL_CNT	R/C	32-bit Complement Code	Times records of voltage swell. The minimum unit is half wave, and the unit can be configured. 24bit effective. When write in any value, can clear zero the counter value.
0x6B	DAT_DIP_CNT	R/C	32-bit Complement Code	Times records of voltage dip. The minimum unit is half wave, and the unit can be configured. 24bit effective. When write in any value, can clear zero the counter value.
0x90	SWELL_REG_MAX_CNT	R/C	32-bit Complement Code	The time recording register for the voltage surge reaching maximum value, with a minimum unit of half a wave and configurable units. 24Bit is valid. Writing any value to this register can reset the count value.
0x91	DIP_REG_MIN_CNT	R/C	32-bit Complement Code	The time recording register for voltage dip reaching minimum value, with a minimum unit of half a wave and configurable units. 24Bit is valid. Writing any value to this register can reset the count value.
0x92	SWELL_REG_MAX	R	32-bit Complement Code	Maximum value of voltage surge.

Address	Register	R/W	Data Format	Description
0x93	DIP_REG_MIN	R	32-bit Complement Code	Minimum value of voltage drop.

2.10 Fast Detection Threshold Register

Table40. Fast detection Threshold Register

Address	Register	R/W	Data Format	Description
0x5B	FD_OVTH	R/W	30-bit Complement Code	To set over-voltage threshold for fast detection. Bit width is 30bit.
0x5C	FD_LVTH	R/W	30-bit Complement Code	To set under-voltage threshold for fast detection. Bit width is 30bit.
0x5D	FD_IA_OCTH	R/W	30-bit Complement Code	To set over-current threshold in channel A for fast detection. Bit width is 30bit.
0x5E	FD_IA_LCTH	R/W	30-bit Complement Code	To set under-current threshold in channel A for fast detection. Bit width is 30bit.
0x5F	FD_IB_OCTH	R/W	30-bit Complement Code	To set over-current threshold in channel B for fast detection. Bit width is 30bit.
0x60	FD_IB_LCTH	R/W	30-bit Complement Code	To set under-current threshold in channel B for fast detection. Bit width is 30bit.

2.11 Waveform Data Register

Table41. Waveform Data Register

Address	Register	R/W	Data Format	Description
0x69	DAT_WAVE	R	32-bit Complement Code	Waveform reading. It can repeatable reading the address and obtain the overall wave data. If there is no need to read all data, it would be reset the bit 31 of

Address	Register	R/W	Data Format	Description
				metering control register (0x07, DSP_CTRL5) to read address.

2.12 Calibration Register

When RSTN pin reset, RX reset, or global software reset occurs, all calibration registers will be reset to the default value. The default value in the following tables of this section are in format of hexadecimal.

All the calibration registers need to be configuration verification and self-checking.

2.12.1 DC Bias Setting Register

Table42. DC Bias Setting Register

Address	Register	Default Value	R/W	Format Value	Description
0x34	DSP_CFG_DCU	0	R/W	32-bit Complement Code	To set the DC compensation for the voltage channel.
0x35	DSP_CFG_DCIA	0	R/W	32-bit Complement Code	To set the DC compensation for the current channel A.
0x36	DSP_CFG_DCIB	0	R/W	32-bit Complement Code	To set the DC compensation for the current channel B.
All registers for calibration need to be configuration verification and self-checking.					

2.12.2 RMS Calibration Register

All numerical formats in the following correction registers are 1-bit signed bits and 31-bit decimal places (negative numbers need to be inverted+1 and placed in the register).

Table43. Voltage/ Current/ Measurement RMS Calibration Register

Address	Register	Default Value	R/W	Data Format	Description
0x2D	DSP_CFG_CALI_RMSU	0	R/W	32-bit Complement Code	To set gain calibration for Voltage RMS.

Address	Register	Default Value	R/W	Data Format	Description
0x2E	DSP_CFG_RMS_DCU	0	R/W	32-bit Complement Code	To set offset calibration for Voltage RMS.
0x2F	DSP_CFG_CALI_RMSIA	0	R/W	32-bit Complement Code	To set gain calibration for Current RMS A.
0x30	DSP_CFG_RMS_DCIA	0	R/W	32-bit Complement Code	To set offset calibration for Current RMS A.
0x31	DSP_CFG_CALI_RMSIB	0	R/W	32-bit Complement Code	To set gain calibration for Current RMS B.
0x32	DSP_CFG_RMS_DCIB	0	R/W	32-bit Complement Code	To set offset calibration for Current RMS.
0x89	FUND_CALI_RMSU	0	R/W	32-bit Complement Code	To set gain calibration for RMS of fundamental voltage
0x8a	FUND_RMS_DCU	0	R/W	32-bit Complement Code	To set gain calibration for RMS of fundamental voltage small signal
0x8b	FUND_CALI_RMSIA	0	R/W	32-bit Complement Code	To set gain calibration for RMS ratio of fundamental current A
0x8c	FUND_RMS_DCIA	0	R/W	32-bit Complement Code	To set gain calibration for fundamental current A RMS small signal
0x8d	FUND_CALI_RMSIB	0	R/W	32-bit Complement Code	To set gain calibration for RMS ratio of fundamental current B
0x8e	FUND_RMS_DCIB	0	R/W	32-bit Complement Code	To set gain calibration for fundamental current B RMS small signal

2.12.3 Power Calibration Register

All numerical formats in the following correction registers are 1-bit signed bits and 31-bit decimal places (negative numbers need to be inverted+1 and placed in the register).

Table44. Total-wave Active/ Reactive Power Calibration Register

Address	Register	Default Value	R/W	Data Format	Description
0x25	DSP_CFG_CALI_PA	0	R/W	32-bit Complement Code	To set gain calibration for the active power A.
0x26	DSP_CFG_DC_PA	0	R/W	32-bit Complement Code	To set offset calibration for the active power A.
0x27	DSP_CFG_CALI_QA	0	R/W	32-bit Complement Code	To set gain calibration for Reactive power A.
0x28	DSP_CFG_DC_QA	0	R/W	32-bit Complement Code	To set offset calibration for Reactive power A.
0x29	DSP_CFG_CALI_PB	0	R/W	32-bit Complement Code	To set gain calibration for Active power B.
0x2A	DSP_CFG_DC_PB	0	R/W	32-bit Complement Code	To set offset calibration for Active power B.
0x2B	DSP_CFG_CALI_QB	0	R/W	32-bit Complement Code	To set gain calibration for Reactive power B.
0x2C	DSP_CFG_DC_QB	0	R/W	32-bit Complement Code	To set offset calibration for Reactive power B.
0x81	FUND_CALI_PA	0	R/W	32-bit Complement Code	To set gain calibration for fundamental active power A
0x82	FUND_DC_PA	0	R/W	32-bit Complement Code	Fundamental active power A small signal correction

Address	Register	Default Value	R/W	Data Format	Description
0x83	FUND_CALI_QA	0	R/W	32-bit Complement Code	To set gain calibration for fundamental reactive power A
0x84	FUND_DC_QA	0	R/W	32-bit Complement Code	Fundamental reactive power A small signal correction
0x85	FUND_CALI_PB	0	R/W	32-bit Complement Code	To set gain calibration for fundamental active power B
0x86	FUND_DC_PB	0	R/W	32-bit Complement Code	Fundamental active power B small signal correction
0x87	FUND_CALI_QB	0	R/W	32-bit Complement Code	To set gain calibration for fundamental reactive power B
0x88	FUND_DC_QB	0	R/W	32-bit Complement Code	Fundamental reactive power B small signal correction

2.12.4 Threshold Register

Table45. Threshold Register

Address	Register	Default Value	R/W	Data Format	Description
0x39	EGY_PROCTH	0	R/W	32-bit Complement Code	Energy accumulator anti-creep threshold. When anti-creep energy accumulator exceeds the EGY_CRPTH and high-speed energy accumulator not exceeds the EGY_PWRTH, the accumulating value of high-speed accumulator will be cleared. Metering chip has a power-creep energy accumulating register for energy accumulator 1 and 2 respectively, and they

Address	Register	Default Value	R/W	Data Format	Description
					<p>have the same accumulation speed. After enabling the power-creep detection in the energy accumulator, the input would be fixed to 1 in this power-creep energy accumulator.</p> <p>User should configure threshold for the power-creep detection register (EGY_CRPTH) and energy accumulating threshold register (EGY_PWRTH). If the accumulating value of power-creep energy accumulator register reaches the value of EGY_CRPTH first, the energy accumulating register will be cleared, and system enter the power-creep status. When the accumulating value of energy accumulating register reaches the value of EGY_PWRTH first, the power-creep energy register will be cleared, system starts to work and operates normally.</p> <p>The actual bit width of register EGY_CRPTH is 32bit. The register contents will be padded with 0s automatically in the 4 least significant bits when the power-creep calculated. It would be calculated after extended to 36 digits.</p>
0x3A	EGY_PWRTH	0	R/W	32-bit Complement Code	Accumulation threshold for energy accumulator. Due to the energy accumulator was 46bit, the accumulated

Address	Register	Default Value	R/W	Data Format	Description
					value of the high-speed energy accumulator equals to this value*16384; the accumulated value of the low-speed energy accumulator equals to this value*4.
0x55	DSP_OV_THL	0	R/W	32-bit Complement Code	To set the lower threshold for the power-creep determination.
0x56	DSP_OV_THH	0	R/W	32-bit Complement Code	To set the upper threshold for the power-creep determination.
0x94	ZERO_TH_U	0	R/W	32-bit Complement Code	After the voltage zero crossing detection threshold function is enabled, this threshold is used to determine whether there is a shielding voltage zero crossing detection. If the effective voltage value is greater than the threshold, voltage zero crossing detection is not shielded; On the contrary, zero crossing detection of shielding voltage.
0x95	ZERO_TH_I	0	R/W	32-bit Complement Code	After the current zero crossing detection threshold function is enabled, this threshold is used to determine whether there is shielding current zero crossing detection. If the RMS of the current is greater than the threshold, the zero crossing detection of the current is not shielded; On the contrary, zero crossing detection of shielding current. The IA and IB channels share this register.

2.12.5 Phase Calibration Register

Table46. Phase Calibration Register (0x33, DSP_CFG_PHC)

Address	Register	Default Value	R/W	Data Format	Description
0x33	DSP_CFG_PHC	0	R/W	32-bit Complement Code	Phase Error Calibration Register. The register needs to be configuration verification and self-checking. [10:0]= phase error calibration value for channel A; [26:16]= phase error calibration value for channel B; Where the range is from -766 to 767.

2.12.6 Bandpass Filter Register

Table47. Bandpass Filter Register (0x37, DSP_CFG_BPF)

Address	Register	Default Value	R/W	Data Format	Description
0x37	DSP_CFG_BPF	0	R/W	32-bit Complement Code	Band-pass filter coefficient. Related to setting the DSP_MODE by Bit[7:4] of metering control register 0 (0x02,DSP_CTRL0) Setting 0x806764B6 at DSP_MODE=0, 1, 2; Setting 0x80DD7A8C at DSP_MODE=6, 7; Setting 0x82B465F0 at DSP_MODE=8. The frequency of other modes would be not supported to measure, so setting to 0x0.

2.13 Checksum Register

Table48. Checksum Register (0x38, DSP_CFG_CKSUM)

Address	Register	Default Value	R/W	Data Format	Description
0x38	DSP_CFG_CKSUM	0	R/W	32-bit Complement Code	<p>This register needs to participate in parameter configuration self-check. This register participates in parameter configuration self-check along with the addresses 0x0 ~ 0x7, 0x25 ~ 0x3A, 0x55 ~ 0x60, 0x80. If all the above register values add up to 0xFFFFFFFF, the parameter configuration self-check passes.</p> <p>To ensure parameter configuration self-check successful, the register should write correct value (0xFFFFFFFF - the sum of the configuration values of other registers participating in the check).</p> <p>After resetting, the self-check does not work, and self-check flag bit is 0.</p> <p>When at least one ADC is turned on, self-check starts working, and self-check flag bit can correctly indicate the current state.</p>

Table49. Self-checking Register

Name	Type	Address	Description	Default
ANA_CTRL0	R/W	0x00	Analog Control Register 0.	0x00000000
ANA_CTRL1	R/W	0X01	Analog Control Register 1.	0x00000000

DSP_CTRL0	R/W	0x02	Metering Control Register 0.	0x00000000
DSP_CTRL1	R/W	0x03	Metering Control Register 1.	0x00000000
DSP_CTRL2	R/W	0x04	Metering Control Register 2.	0x00000000
DSP_CTRL3	R/W	0x05	Metering Control Register 3.	0x00000000
DSP_CTRL4	R/W	0x06	Metering Control Register 4.	0x00000000
DSP_CTRL5	R/W	0x07	Metering Control Register 5.	0x00000000
DSP_CFG_CALI_PA	R/W	0x25	To set gain calibration for the active power A.	0x00000000
DSP_CFG_DC_PA	R/W	0x26	To set offset calibration for the active power A.	0x00000000
DSP_CFG_CALI_QA	R/W	0x27	To set gain calibration for Reactive power A.	0x00000000
DSP_CFG_DC_QA	R/W	0x28	To set offset calibration for Reactive power A.	0x00000000
DSP_CFG_CALI_PB	R/W	0x29	To set gain calibration for Active power B.	0x00000000
DSP_CFG_DC_PB	R/W	0x2A	To set offset calibration for Active power B.	0x00000000
DSP_CFG_CALI_QB	R/W	0x2B	To set gain calibration for Reactive power B.	0x00000000
DSP_CFG_DC_QB	R/W	0x2C	To set offset calibration for Reactive power B.	0x00000000
DSP_CFG_CALI_RMSU	R/W	0x2D	To set gain calibration for Voltage RMS.	0x00000000
DSP_CFG_RMS_DCU	R/W	0x2E	To set offset calibration for Voltage RMS.	0x00000000
DSP_CFG_CALI_RMSIA	R/W	0x2F	To set gain calibration for Current RMS A.	0x00000000
DSP_CFG_RMS_DCIA	R/W	0x30	To set offset calibration for Current RMS A.	0x00000000
DSP_CFG_CALI_RMSIB	R/W	0x31	To set gain calibration for Current RMS B.	0x00000000
DSP_CFG_RMS_DCIB	R/W	0x32	To set offset calibration for Current RMS.	0x00000000
DSP_CFG_PHC	R/W	0x33	Phase Error Calibration Registers. [10:0]= phase error calibration value for channel A [26:16]= phase error calibration value for channel B.	0x00000000

			Where the range is from -766 to 767.	
DSP_CFG_DCU	R/W	0x34	To set the DC compensation for the voltage channel.	0x00000000
DSP_CFG_DCIA	R/W	0x35	To set the DC compensation for the current channel A.	0x00000000
DSP_CFG_DCIB	R/W	0x36	To set the DC compensation for the current channel B.	0x00000000
DSP_CFG_BPF	R/W	0x37	Band-pass filter coefficient. Related to setting the DSP_MODE by Bit[7:4] of metering control register 0 (0x02,DSP_CTRL0). Setting 0x806764B6 at DSP_MODE=0,1,2; setting 0x80DD7A8C at DSP_MODE=6,7; setting 0x82B465F0 at DSP_MODE=8. The frequency of other modes would be not supported to measure, so setting to 0x0.	0x00000000
DSP_CFG_CKSUM	R/W	0x38	Configuration register for checksum.	0x00000000
EGY_PROCTH	R/W	0x39	Anti-creep threshold for energy accumulator. When the accumulated value of the anti-creep energy accumulator over this threshold and the accumulated value of the high-speed energy accumulator under this threshold, the accumulated value of the high-speed energy accumulator will be cleared.	0x00000000
EGY_PWRTH	R/W	0x3A	Accumulation threshold for energy accumulator. Due to the energy accumulator was 46bit, the accumulated value of the high-speed energy accumulator equals to this value*16384; the accumulated value of the low-	0x00000000

			speed energy accumulator equals to this value*4.	
DSP_OV_THL	R/W	0x55	To set the lower threshold for the no-load determination.	0x00000000
DSP_OV_THH	R/W	0x56	To set the upper threshold for the no-load determination.	0x00000000
DSP_SWELL_THL	R/W	0x57	To set the lower threshold for the voltage dip.	0x00000000
DSP_SWELL_THH	R/W	0x58	To set the upper threshold for the voltage swell.	0x00000000
DSP_DIP_THL	R/W	0x59	To set the lower threshold for the voltage dip.	0x00000000
DSP_DIP_THH	R/W	0x5A	To set the upper threshold for the voltage swell.	0x00000000
FD_OVTH	R/W	0x5B	To set over-voltage threshold for fast detection. Bit width is 30bit.	0x00000000
FD_LVTH	R/W	0x5C	To set under-voltage threshold for fast detection. Bit width is 30bit.	0x00000000
FD_IA_OCTH	R/W	0x5D	To set over-current threshold in channel A for fast detection. Bit width is 30bit.	0x00000000
FD_IA_LCTH	R/W	0x5E	To set under-current threshold in channel A for fast detection. Bit width is 30bit.	0x00000000
FD_IB_OCTH	R/W	0x5F	To set over-current threshold in channel B for fast detection. Bit width is 30bit.	0x00000000
FD_IB_LCTH	R/W	0x60	To set under-current threshold in channel B for fast detection. Bit width is 30bit.	0x00000000
DSP_CTRL6	R/W	0x80	Metering Control Registers 6.	0x00000000

3 Main Power Supply

Features of V93XX main power system as below:

- 3.3V single main power supply, the voltage input range: 2.6~3.6V
- The power supply of the internal digital circuit comes from the Digital main power circuit (DVCC/LDO)
- The power supply of the oscillator circuit comes from 3.3V main power
- Supporting power down detection
- Controllable CF detection of power down alarm

Figure5. Main Power System

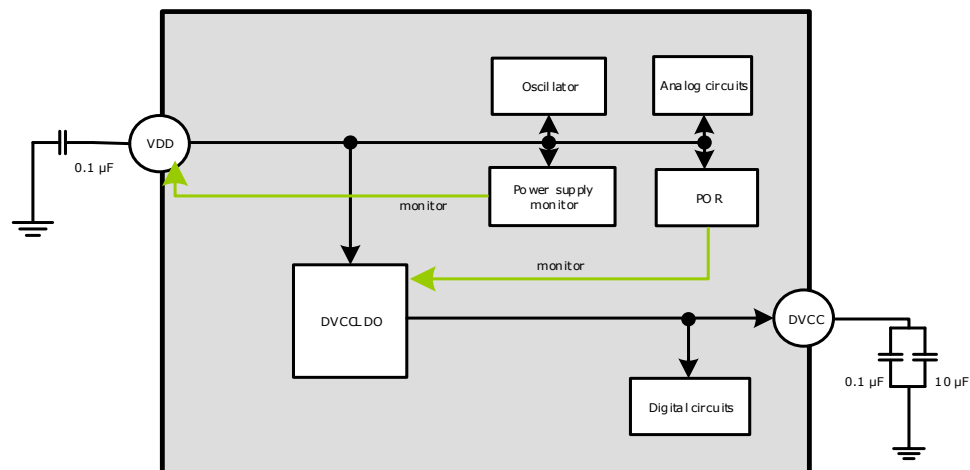

3.1 Power Supply Monitoring Circuit

V93XX integrates an internal power-down detection circuit to supervise the voltage on pin “VDD” all the time. When the voltage on the pin “VDD” is lower than 2.8V ($\pm 7\%$), the power-down interrupt would be generated. The power supply monitoring circuit is always on work.

Figure6. Power-down monitoring

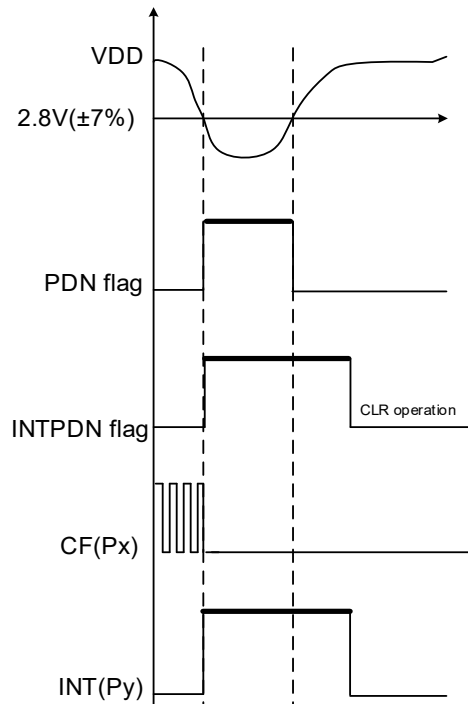

3.2 Digital Power Supply

V93XX integrates an on-chip LDO (DVCCLDO) and supplies voltage for digital circuit. This circuit could output stable voltage with the power supply (VDD) has ripple noise. LDO is always on work.

The DVCCLDO has a driving capability of 35 mA. When the load current on the digital circuits is less than 35 mA, the DVCCLDO outputs stable voltage. When the load current is higher than 35mA, the output voltage reduces as the current increases.

4 Bandgap circuit

In the V93XX, the Bandgap circuit outputs a reference voltage and bias current, about 1.21V with a typical temperature coefficient of 10 ppm/°C, for ADCs and the 6.5 MHz RC oscillator. By default, the Bandgap circuit was enabled. This circuit consumes about 0.09 mA (typical).

Users can configure RESTL<1:0> (Bit[4:3]) and REST<2:0> (Bit[2:0]) of analog control register (0x01, ANA_CTRL1) to adjust the temperature coefficient of Bandgap circuit to cancel the temperature coefficient introduced by the external components, with the following steps:

1. Assume the current settings of relative bits are REST<2:0>='010' and RESTL<1:0>='00', which corresponds to the temperature coefficient of Bandgap is +14 ppm.
2. Measure meter errors in high and low temperature conditions. For example, this meter has 0 error at 20°C, and the measuring errors are 0.6% at 80°C and -0.4% at -40°C respectively. Then a $-(0.6\% - (-0.4\%))/2 = -0.5\%$ measuring error needs to be compensated relative to high temperature working condition, equivalent to $-0.5\% / (80 - 20) = -5000/60 = -83$ ppm.
3. As measured error is minus two times of Reference temperature coefficient error, to compensate a -83 ppm error, an additional +41.5 ppm of Bandgap REF temperature coefficient adjustment is needed. Taking the initial +14 ppm setting into consideration, the actual adjustment should be +55.5 ppm. According to the lookup table of RESTL<1:0> and REST<2:0>, user should set register RESTL<1:0> to '11' and REST<2:0> to '000', whose combination equals to a +56 ppm temperature coefficient adjustment.

Attention: For the adjustment of Reference temperature parameters would influence the basic error; therefore, when customers designed each new product, please first confirm the temperature parameter of Reference then calibrate the error of the meter.

Note1: A temperature coefficient drift of x in the Bandgap circuit results in a drift of $-2x$ in the measurement error.

Table50. Register for Bandgap Circuit

Register	Bit	Default Value	Description
ANA_CTRL1	Bit[4:3] RESTL<1:0>	0	To roughly adjust the temperature coefficient of the Bandgap circuit. 00: 0 ppm 01: -58 ppm 10: +111 ppm 11: +56 ppm In order to obtain the best metering performance and temperature performance during normal metering, it must be iterated according to the calculated result.

Register	Bit	Default Value	Description
	Bit[2: 0] REST<2:0>	0	<p>To finely adjust the temperature coefficient of the Bandgap circuit</p> <p>000: 0 ppm 001: +7 ppm 010: +14 ppm 011: +28 ppm 100: -32 ppm 101: -21 ppm 110: -14 ppm 111: -7 ppm</p> <p>In order to obtain the best metering performance and temperature performance during normal metering, it must be iterated according to the calculated result.</p>

5 Clock

The on-chip RC oscillator circuit and the external input clock provide clocks for the V93XX:

- An external 6.5536 MHz of the pins “CTI”, “CLK1”. After the frequency divider, SDIV, controlled by DSP_MODE (Bit<7:4>, Metering Control Register 0 (0x02, DSP_CTRL0)). This clock source for all digital block uses. After the frequency divider, ADIV, controlled by ADCKSEL (Bit25<31:30>, analog control register, 0x01, ANA_CTRL1). This clock source for ADC uses. After RSTN pin reset, RX reset, or global software reset, this oscillator circuit starts to run automatically.
- On-chip 6.5 MHz (The deviation is within ±20% from chip to chip for mass production. The temperature deviation from -40~85 degree for each specific chip is less than ±5%.) RC oscillator generates the clock, “CLK2”. When the CTI external input clock was disabled, it would be an optional clock source for digital block uses. This circuit can be disabled.
- On-chip 8 KHz (±50%) RC oscillator generates the clock,” CLK3”. This clock source for IO ports filter use. This circuit keeps on working until the system is powered off.
- External CLK (32768 Hz), input from X32KIN pin. This clock source for low-speed energy accumulator uses. The clock source of energy accumulator would be controlled by EGY_CLK_SEL (bit23, metering control register 1 (Metering Control Register 2 (0x03, DSP_CTRL1))).

As mentioned above, the relationship between the 4 clocks source as the shown below:

Figure7. Clock generation

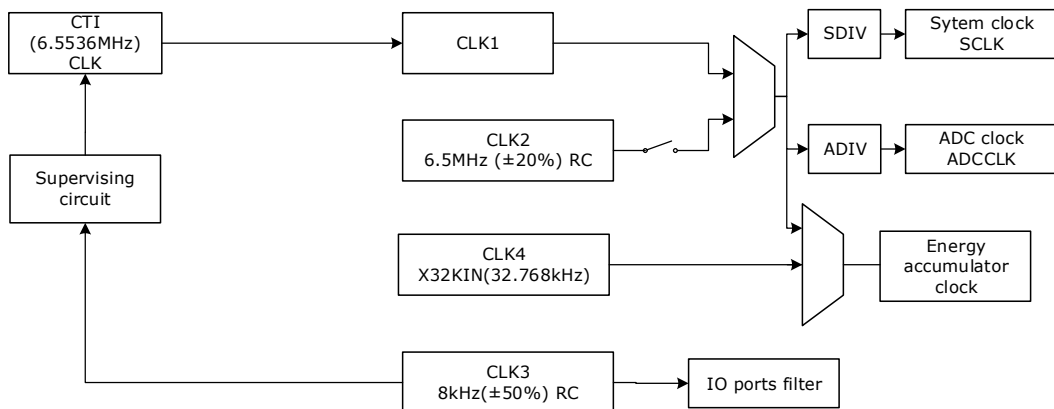

Table51. Clock Generation Related Registers

Register	Bit	Default Value	Description
ANA_CTRL1	Bit7 XRST_PD	0	The external input CTI clock enable. 0: enable 1: disable
	Bit[22] RCCLK_PD	0	To enable the 6.5-MHz RC clock. 0: enable 1: disable The bit must be set to 0 for proper operation.
	Bit[23] XTALPD	0	To disable the CTI external input clock by set this bit to 1. By default, this circuit is enabled.
	Bit[29:24] RCTRIM<5:0>	0	To adjust the 6.5M RC frequency. 000000~011111: step-up the frequency by 1.25% 100000~111111: step-down the frequency by 1.25%
ANA_CTRL1	Bit[31:30] ADCKSEL<1:0>	0	To select the clock frequency for the ADC. 00 corresponds to 819.2 KHz. 00: ×1 01: ×2 10: ×1/4 11: ×1/2
	DSP_CTRL0 (Metering Control Register 0 (0x02, DSP_CTRL0))	0	DSP Operating Mode. 0: 128 sampling points per cycle by DSP at 6.5536 MHz system clock 1: 64 sampling points per cycle by DSP at 6.5536 MHz system clock 2: 32 sampling points per cycle by DSP at 6.5536 MHz system clock. 3, 4, and 5: Reserved. 6: 64 sampling points per cycle by DSP at 3.2768 MHz system clock 7: 32 sampling points per cycle by DSP at 3.2768 MHz system clock 8: 32 sampling points per cycle by DSP at 819.2 KHz system clock (At this time, only RMS calculation is supported, users can select RMS channel through DSP_CTRL6
	Bit[7:4] DSP_MODE<3:0>	0	

Register	Bit	Default Value	Description
			register.) 9: 16 sampling points per cycle by DSP at 409.6 KHz system clock (At this time, only RMS calculation is supported, users can select RMS channel through DSP_CTRL6 register.) Others: the same as mode 0
DSP_CTRL1 (Metering Control Register 2 (0x03, DSP_CTRL1))	Bit23 EGY_CLK_SEL	0	To selection the clock for Energy accumulator. It needs the stable time around 107 us when CLK switch over. Please disable CF before it is stable. 0: 204.8 KHz 1: 32768 Hz

5.1 External input high-frequency clock

V93XX provides CLK1 clock for system, metering VMA, ADC, UART/SPI interfaces, and energy accumulators. The CLK1 clock comes from the CTI pin input.

Users can apply a 6.5536MHz clock outside the CTI pin. If you need to switch to the external clock, you need to configure the analog control register (0x01, ANA_CTRL1) to enable the external clock. After enabling it automatically switch to the external clock mode.

When the RCH clock is used instead of the CLK1 clock, two modes of application are supported at this time: the energy accumulator function is not used; alternatively, a 32768 Hz frequency clock is input through the X32KIN pin to be used as the clock for the energy accumulator.

5.2 High-Frequency RC Oscillator

V93XX provides CLK2 clock for system, metering VMA, ADC, UART/SPI interfaces, and energy accumulators. The system clock defaults to using the CLK2 clock, which comes from the RCH clock. The V93XX has an internal high-frequency 6.5 MHz RC oscillator (The deviation is within ±20% from chip to chip for mass production. The temperature deviation from Celsius -40~85 degree for each specific chip is less than ±5 %.)

Under the metering mode, when CTI external input clock error, the RCH clock (CLK2) to work as an optional clock source for digital circuits.

When using RCH clock (CLK2) as system clock, two modes of application are supported: the energy bucket function is not used; choose to use the X32KIN pin to inject a 32768Hz frequency

clock as the energy bucket clock.

After RSTN pin reset, RX reset, or global software reset, this circuit and Bandgap circuit will be working automatically.

For the convenience of debugging and testing, the RCH clock can be output through the Px pin. SYS_IOCFGx needs to be configured and set RCH_OUT_EN (0x80, DSP_CTRL6). Due to the definition of clock output as the third type of interrupt output, it is necessary to disable other interrupts in order to output the clock signal separately.

5.3 Low-Frequency RC Oscillator

V93XX the low-frequency RC oscillator can generate a 8 KHz ($\pm 50\%$) RC clock (CLK3) to drive the IO ports filter (RSTN/ RX/ A0/ A1 pin) for using the signal input.

This oscillator is always on work until the system is powered off.

For the convenience of debugging and testing, the RCH clock can be output through the Px pin. SYS_IOCFGx needs to be configured and set RCH_OUT_EN (0x80, DSP_CTRL6). Due to the definition of clock output as the third type of interrupt output, it is necessary to disable other interrupts in order to output the clock signal separately.

5.4 External Input Clock

The external can inject a 32768 Hz frequency clock into the X32KIN pin of V93XX to provide CLK4 clock for low-speed accumulation of energy barrel of V93XX.

6 RESET

6.1 Reset Related Registers

Table52. Reset Related Registers

Register	Bit	Description																				
0x74 SYS_STS	Bit[22:20] RST_SOURCE	Flag bits to indicate the reset source																				
		<table border="1"> <thead> <tr> <th>Bit22</th> <th>Bit21</th> <th>Bit20</th> <th>Description</th> </tr> </thead> <tbody> <tr> <td>0</td> <td>0</td> <td>1</td> <td>Reserved.</td> </tr> <tr> <td>0</td> <td>1</td> <td>0</td> <td>A RSTN event occurred.</td> </tr> <tr> <td>0</td> <td>1</td> <td>1</td> <td>An RX reset event occurred.</td> </tr> <tr> <td>1</td> <td>0</td> <td>0</td> <td>A global software reset occurred.</td> </tr> </tbody> </table>	Bit22	Bit21	Bit20	Description	0	0	1	Reserved.	0	1	0	A RSTN event occurred.	0	1	1	An RX reset event occurred.	1	0	0	A global software reset occurred.
		Bit22	Bit21	Bit20	Description																	
		0	0	1	Reserved.																	
		0	1	0	A RSTN event occurred.																	
0	1	1	An RX reset event occurred.																			
1	0	0	A global software reset occurred.																			
0x6c, SFTRST Software Reset Control Register		Writable only, in the form of 32-bit 2' complement. Write "0x4572BEAF" to the register to reset the system and all circuit is back to initial state.																				

6.2 External Reset

In V93XX, the external reset circuit supervises the status on pin "RSTN" all the time. When the input on pin "RSTN" must be driven low for at least 2 ms to force the chip into the reset state. Pull to the logic high, and 900µs later the chip will exit from the reset state and get back to the Default State.

When a RSTN event occurs, the bit "RST_SOURCE" (Bit[22:20], 0x74, SYS_STS) will be reset to "0b010".

In the reset state, the master MCU and the VMA metering architecture cannot access RAM. When the chip exits from the reset state, RAM will implement the self-checking in about 1.25 ms. If there is no error occurring, RAM can be accessed.

In the reset state, the UART/ SPI serial interface is idle. The UART/SPI serial interface starts to run immediately once the chip exits from the reset state.

Figure8. Timing for RSTN

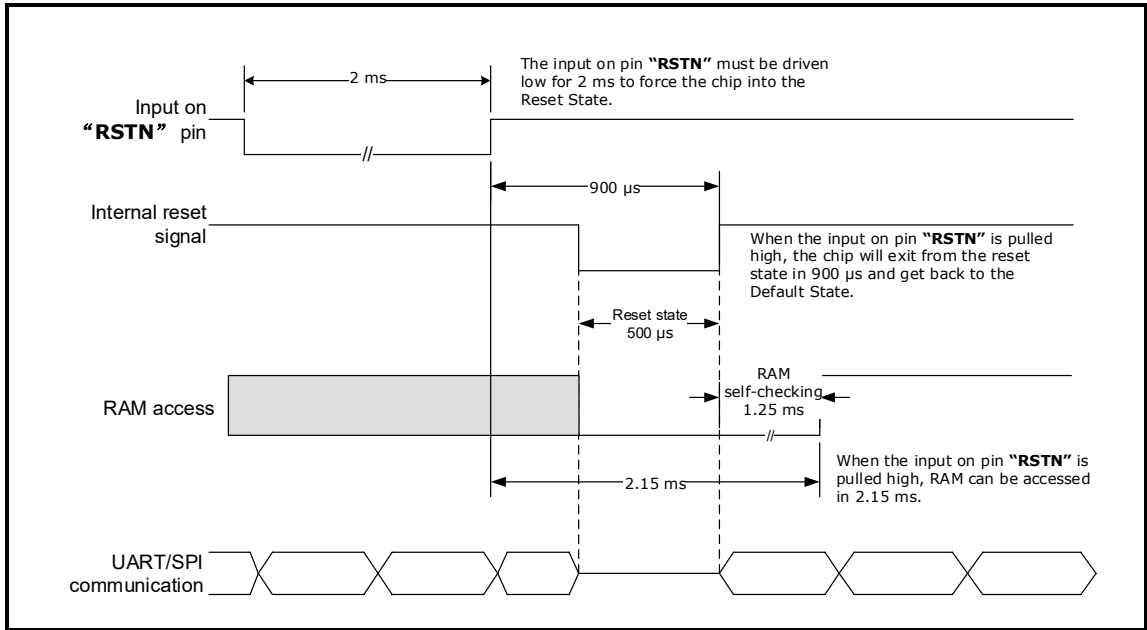

6.3 RX Reset

“RX” reset depends on the communication type.

In the UART mode, when the “RX/ MOSI” pin continuously inputs a low level of 128 ms to force the chip into the reset state. Pull to the logic high, and 900 μs later the chip will exit from the reset state and get back to the Default State.

In the SPI mode, when the “RX/ MOSI” pin and “A1/ SPCSN” pin continuously inputs a low level of 128 ms and fed a clock source on pin “A0/ SPCK” which the frequency above the 50 Hz, then force the chip into the reset state. Pull to the logic high, and 900 μs later the chip will exit from the reset state and get back to the Default State

When the “RX” reset occurs, the bit “RST_SOURCE” (Bit[22:20], 0x74, SYS_STS) will be reset to “0b011”.

In the reset state, the master MCU and the VMA metering architecture cannot access RAM. When the chip exits from the reset state, RAM will implement the self-checking in about 1.25 ms. If there is no error occurring, RAM can be accessed.

In the reset state, the UART/SPI serial interface is idle. The UART/SPI serial interface starts to run immediately once the chip exits from the reset state.

Note: After the chip is powered on, an RX reset operation needs to be performed once.

Figure9. Timing for RX Reset of UART

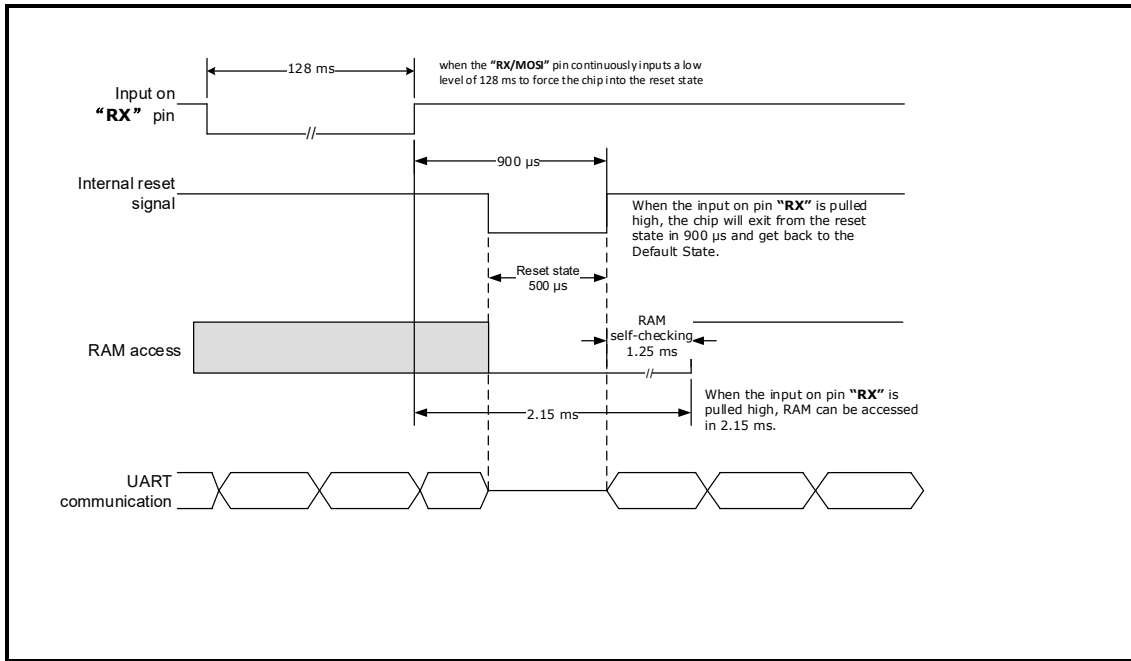
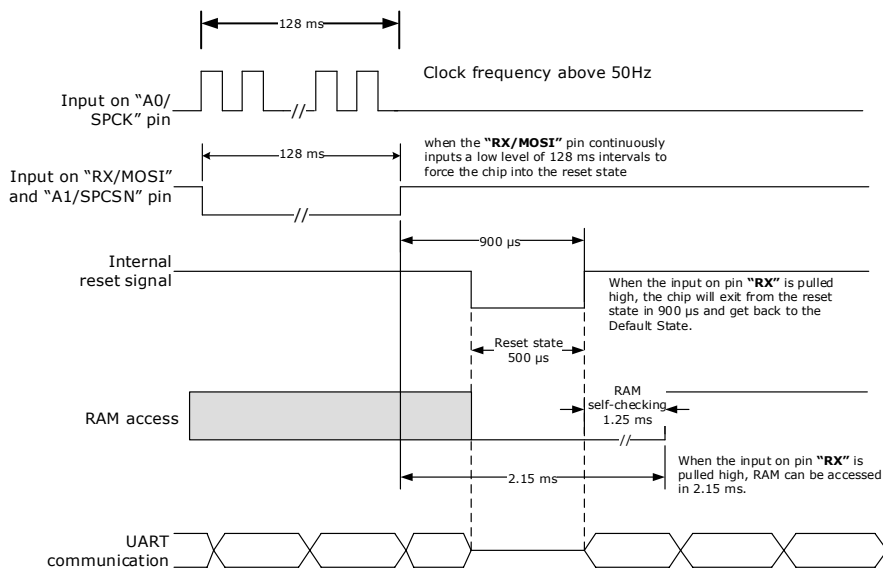

Figure10. Timing for RX Reset of SPI



6.4 Global Software Reset

Under the condition that the system communication is normal, writing of **“0x4572BEAF”** in the register **“SYS_SFTRST”** (0x6C) can force the chip into the Reset State, and the chip will exit and get back to Default State in 650 μs.

When the global software reset occurs, the bit “RST_SOURCE” (Bit[22:20], 0x74, SYS_STS) will be reset to “0b100”.

In the Reset State, the master MCU and the VMA metering architecture cannot access RAM. When the chip exits from the Reset State, RAM will implement the self-checking in about 1.25ms. If there is no error occurring, RAM can be accessed.

In the Reset State, the UART serial interface is idle. The UART serial interface starts to run immediately once the chip exits from the Reset State.

Figure11. Timing of Global Software Reset

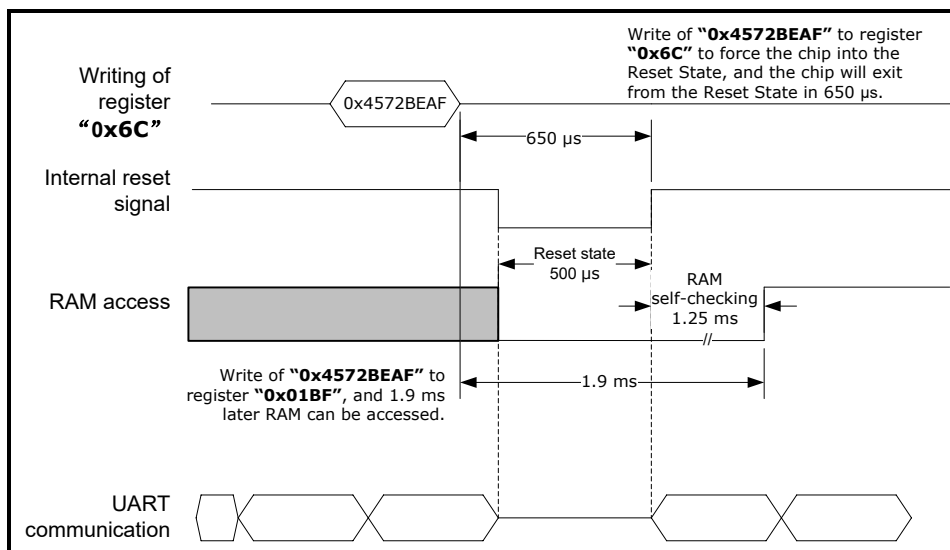

7 UART

7.1 Overview

V93XX supports two communication modes, UART and SPI, which can switch between SPI communication and UART communication without using external hardware jumper. After RSTN reset, RX reset or soft reset, V93XX uses UART communication by default. If you want to communicate by SPI, you must initialize the SPI interface once through the SPI protocol.

The UART serial interface has features:

- asynchronous, half-duplex communication;
- a 11-bit byte, composed of 1-bit Start bit, 8-bit Data bits, 1-bit Parity bit (odd), and 1-bit Stop bit;
- least significant bit (lsb) shifted in or out firstly when the chip receives or transmits a byte.

Support multi-machine mode, that is, when the output data port is idle, it is a high resistance state. Up to 4 V93XX share a single data bus via physical addresses A0 and A1.

The data byte received and transmitted via the UART serial interface of the V93XX is composed of 11 bits, including 1-bit start bit (logic low), 8-bit data bits, 1-bit odd parity bit and 1-bit stop bit (logic high), as shown in the following figure. When the V93XX sends command, the least significant bit and least significant byte always are shifted out firstly.

Figure12. Structure of an 11-Bit data byte (from LSB to MSB)



UART protocol is a half-duplex protocol. The end of the send command for 1ms later, then V93XX would upload data.

UART supports 1200bps to 19200bps baud rate and it can self-adapting the baud rate which received from the first frame header. The baud rate will also be fine-tuned through the following communication. If the baud rate of communication has a large change, it needs rerunning the baud rate self-adapting. Before this event, it needs to set the UARTAUTOEN Bit0 of SYS_MISC to 1.

V93XX also has the command for continually writing or broadcast writing. This mode can save the parameter configurable time.

Under the following conditions, the UART transmission will be aborted and back to IDLE state.

Table53. UART communication errors

No	Conditions	UARTERR set to 1
1	UART frame header error.	NO
2	UART overtime, each 2 Bytes needs to shorter than 20 ms.	YES
3	UART parity bit error.	YES
4	UART sends checksum byte from master MCU has error.	YES

7.2 Communication Protocol

In read or write operation, when the V93XX receives the command frame from the master MCU, it will reply to the master MCU with a respond frame of different structures. In broadcast communication, the V93XX will not reply to the master MCU to avoid communication conflict.

The following figure depicts the timing of UART communication.

Figure13. Timing of UART Communication

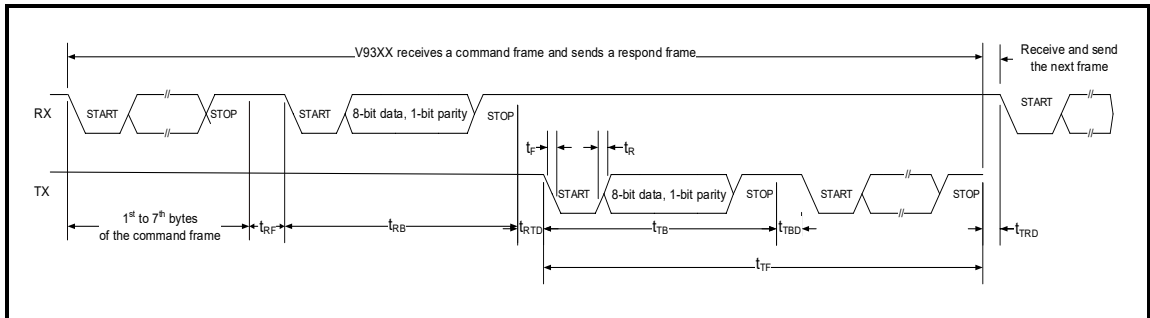

Table54. UART Communication Timing Parameters

Parameter	Description
t _{RB}	Time to receive a data byte on pin RX. $t_{RB} = \frac{11}{\text{baudrate}}$ where, <i>baudrate</i> is the actual baud rate.
t _{RF}	The maximum time between two bytes when receiving a command frame on pin “RX” $t_{RF} = \frac{16}{\text{baudrate}}$ Where, <i>baudrate</i> is the actual baud rate. <i>Baudrate</i> =4800bps, t _{RF} =3.33ms. After a timeout event, the UART serial interface is idle and waits for the next command frame.

Parameter	Description
t _{RTD}	The delay between command frame reception on pin RX and respond frame transmission on pin TX. $0ms \leq t_{RTD} \leq 20ms$ Please note no respond frame will be transmitted in broadcast communication, and at least 2ms delay is recommended between two continuous command frames for broadcast communications.
t _{TF}	Time to transmit a respond frame in read or write operation, depending on the structure of the frame.
t _{TB}	Time to transmit a data byte. $t_{TB} = \frac{11}{\text{baudrate}}$ where <i>baudrate</i> is the actual baud rate.
T _{TBD}	Delay between two continuous data bytes in a respond frame. $0ms \leq t_{TBD} \leq 20ms$
t _{TRD}	The delay between respond frame transmission on pin TX and the next command frame reception on pin RX. More than 2ms is recommended.
t _R	Rise time of RX and TX, about 300ns.
t _F	Fall time of RX and TX, about 300ns.

7.3 Broadcast Communication

- --Supports writing to consecutive registers of 1~16 addresses
- --Don't care about device address{A1,A0}
- --V93XX no response

Batch writes to register for multiple V93XX devices via broadcast writing by master MCU. This mode can save the parameter configurable time. The figure below is the command frame for broadcast writing operation.

Figure14. command frame for broadcast writing operation



Table55. Structure of Data Byte (B7:B0) From Master MCU to V93XX on Broadcast Operation

Order	Byte	B7	B6	B5	B4	B3	B2	B1	B0
1	HEADER	0	1	1	1	1	1	0	1
2	CMD1	To select the data length on				X*	X*	0	0

Order	Byte	B7	B6	B5	B4	B3	B2	B1	B0
		broadcast writing (N) 0: write 1 data of 32 bits 1: write 2 data of 32 bits ... 15: write 16 data of 32 bits							
3	CMD2	Start address for broadcast writing operation (D ₀)							
4	Data 0 Byte 0	"Bit[7:0]" of the target data write into register (address D ₀)							
5	Data 0 Byte 1	"Bit[15:8]" of the target data write into register (address D ₀)							
6	Data 0 Byte 2	"Bit[23:16]" of the target data write into register (address D ₀)							
7	Data 0 Byte 3	"Bit[31:24]" of the target data write into register (address D ₀)							
8	CKSUM 0	Checksum 0. Add the above 4 target data bytes (Data 0 Byte 0~3), CMD1, and CMD2, invert the sum, and then add it to "0x33" to obtain the checksum. The equation is as below: CKSUM 0 = 0x33 + ~(CMD1 + CMD2 + Data 0 Byte 0 + Data 0 Byte 1 + Data 0 Byte 2 + Data 0 Byte 3)							
...							
5xN+4	Data N Byte 0	"Bit[7:0]" of the target data write into register (address D _N =D ₀ +N)							
5xN+5	Data N Byte 1	"Bit[15:8]" of the target data write into register (address D _N =D ₀ +N)							
5xN+6	Data N Byte 2	"Bit[23:16]" of the target data write into register (address D _N =D ₀ +N)							
5xN+7	Data N Byte 3	"Bit[31:24]" of the target data write into register (address D _N =D ₀ +N)							
5xN+8	CKSUM N	Checksum N. Add the above 4×(N+1) target data bytes (Data 0~N Byte 0~3), CMD1, and CMD2, invert the sum, and then add it to "0x33" to obtain the checksum. The equation is as below: CKSUM N = 0x33 + ~(CMD1 + CMD2 + Data 0 Byte 0 + Data 0 Byte 1 + Data 0 Byte 2 + Data 0 Byte 3 + + Data N Byte 0 + Data N Byte 1 + Data N Byte 2 + Data N Byte 3)							
If the length N equals to 0 on broadcast writing operation, master MCU only sends first 8 bytes of command frame to V93XX.									

7.4 Read Operation

- Supports writing to consecutive registers of 1~16 addresses
- device address {A1,A0} must be matched correctly
- V93XX would be responded

Figure15. Communication protocol for read operation

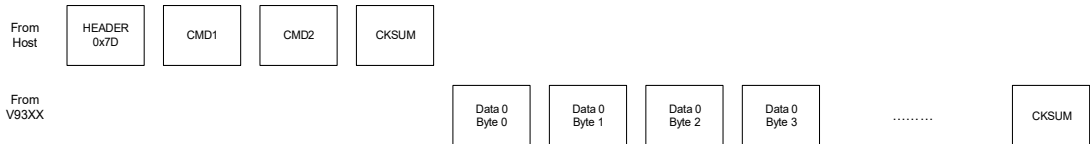

Table56. Structure of Data Byte (B7:B0) From Master MCU to V93XX on Read Operation

Order	Byte	B7	B6	B5	B4	B3	B2	B1	B0
1	HEADER	0	1	1	1	1	1	0	1
2	CMD1	To select the data length on read operation 0: write 1 data of 32 bits 1: write 2 data of 32 bits ... 15: write 16 data of 32 bits				A1	A0	0	1
3	CMD2	Start address for read operation (D ₀)							
4	CKSUM	Checksum. Add the above CMD1 and CMD2, invert the sum, and then add it to “0x33” to obtain the checksum. The equation is as below: CKSUM = 0x33 + ~(CMD1 + CMD2)							

Table57. Structure of Data Byte (B7:B0) From V93XX to Master MCU on read Operation

Order	Byte	B7	B6	B5	B4	B3	B2	B1	B0
1	Data 0 Byte 0	“Bit[7:0]” of the target data read from register (address D ₀)							
2	Data 0 Byte 1	“Bit[15:8]” of the target data read from register (address D ₀)							
3	Data 0 Byte 2	“Bit[23:16]” of the target data read from register (address D ₀)							
4	Data 0 Byte 3	“Bit[31:24]” of the target data read from register (address D ₀)							
...							
4xN+1	Data N	“Bit[7:0]” of the target data read from register (address D _N =D ₀ +N)							

Order	Byte	B7	B6	B5	B4	B3	B2	B1	B0
	Byte 0								
4xN+2	Data N Byte 1	"Bit[15:8]" of the target data read from register (address $D_N=D_0+N$)							
4xN+3	Data N Byte 2	"Bit[23:16]" of the target data read from register (address $D_N=D_0+N$)							
4xN+4	Data N Byte 3	"Bit[31:24]" of the target data read from register (address $D_N=D_0+N$)							
4xN+5	CKSUM	Checksum. Add the above $4 \times (N+1)$ target data bytes (Data 0~N Byte 0~3, comes from V93XX), CMD1, and CMD2(comes from MCU), invert the sum, and then add it to "0x33" to obtain the checksum. The equation is as below: $CKSUM = 0x33 + \sim(CMD1 + CMD2 + Data\ 0\ Byte\ 0 + Data\ 0\ Byte\ 1 + Data\ 0\ Byte\ 2 + Data\ 0\ Byte\ 3 + \dots + Data\ N\ Byte\ 0 + Data\ N\ Byte\ 1 + Data\ N\ Byte\ 2 + Data\ N\ Byte\ 3)$							
If the length N equals to 0 on read operation, V93XX only sends 5 bytes of response frame to master MCU.									

7.5 Write Operation

- Supports writing to consecutive registers of 1~16 addresses
- device address {A1, A0} must be matched correctly
- V93XX would be responded

Figure16. Communication protocol for write operation

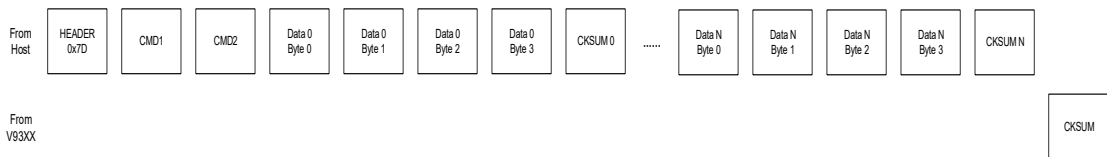

Table58. Structure of Data Byte (B7:B0) From Master MCU to V93XX on Write Operation

Order	Byte	B7	B6	B5	B4	B3	B2	B1	B0
1	HEADER	0	1	1	1	1	1	0	1
2	CMD1	To select the data length on write operation 0: write 1 data of 32 bits 1: write 2 data of 32 bits ...				A1	A0	1	0

Order	Byte	B7	B6	B5	B4	B3	B2	B1	B0
		15: write 16 data of 32 bits							
3	CMD2	Start address for write operation (D ₀)							
4	Data 0 Byte 0	"Bit[7:0]" of the target data write into register (address D ₀)							
5	Data 0 Byte 1	"Bit[15:8]" of the target data write into register (address D ₀)							
6	Data 0 Byte 2	"Bit[23:16]" of the target data write into register (address D ₀)							
7	Data 0 Byte 3	"Bit[31:24]" of the target data write into register (address D ₀)							
8	CKSUM 0	Checksum 0. Add the above 4 target data bytes (Data 0 Byte 0~3), CMD1, and CMD2, invert the sum, and then add it to "0x33" to obtain the checksum. The equation is as below: CKSUM 0 = 0x33 + ~(CMD1 + CMD2 + Data 0 Byte 0 + Data 0 Byte 1 + Data 0 Byte 2 + Data 0 Byte 3)							
...							
5xN+4	Data N Byte 0	"Bit[7:0]" of the target data write into register (address D _N =D ₀ +N)							
5xN+5	Data N Byte 1	"Bit[15:8]" of the target data write into register (address D _N =D ₀ +N)							
5xN+6	Data N Byte 2	"Bit[23:16]" of the target data write into register (address D _N =D ₀ +N)							
5xN+7	Data N Byte 3	"Bit[31:24]" of the target data write into register (address D _N =D ₀ +N)							
5xN+8	CKSUM N	Checksum N. Add the above 4×(N+1) target data bytes (Data 0~N Byte 0~3), CMD1, and CMD2, invert the sum, and then add it to "0x33" to obtain the checksum. The equation is as below: CKSUM N = 0x33 + ~(CMD1 + CMD2 + Data 0 Byte 0 + Data 0 Byte 1 + Data 0 Byte 2 + Data 0 Byte 3 + + Data N Byte 0 + Data N Byte 1 + Data N Byte 2 + Data N Byte 3)							
If the length N equals to 0 on broadcast writing operation, master MCU only sends first 8 bytes of command frame to V93XX.									

Table59. Structure of Data Byte (B7:B0) From V93XX to Master MCU on Write Operation

Order	Byte	B7	B6	B5	B4	B3	B2	B1	B0
1	CKSUM	Checksum (comes from V93XX). Used to verify that the write operation was successful.							

Order	Byte	B7	B6	B5	B4	B3	B2	B1	B0
		If CKSUM and CKSUM N (comes from master MCU) was equal, this time write operation was succeeded. If CKSUM and CKSUM N (comes from master MCU) was not equal, this time write operation was failed.							

7.6 Block Reading Operation

In order to facilitate the user to read the required data at one time and improve communication efficiency, V93XX provides address mapping function: The user maps the address of the data item that needs to be continuously operated to the address register, so that the user can perform the block read operation on the data in different places by operating the address register.

Up to 16 data register addresses can be mapped.

The block reading operation can start from any position in the mapped address register. If the address plus the number of reads exceeds the buffer size, the read is started from the beginning. For example, 10 data are read from the 13th mapping address, and after the 16th address, the data of 6 addresses is continuously read from the first one.

Figure17. address mapping for block reading

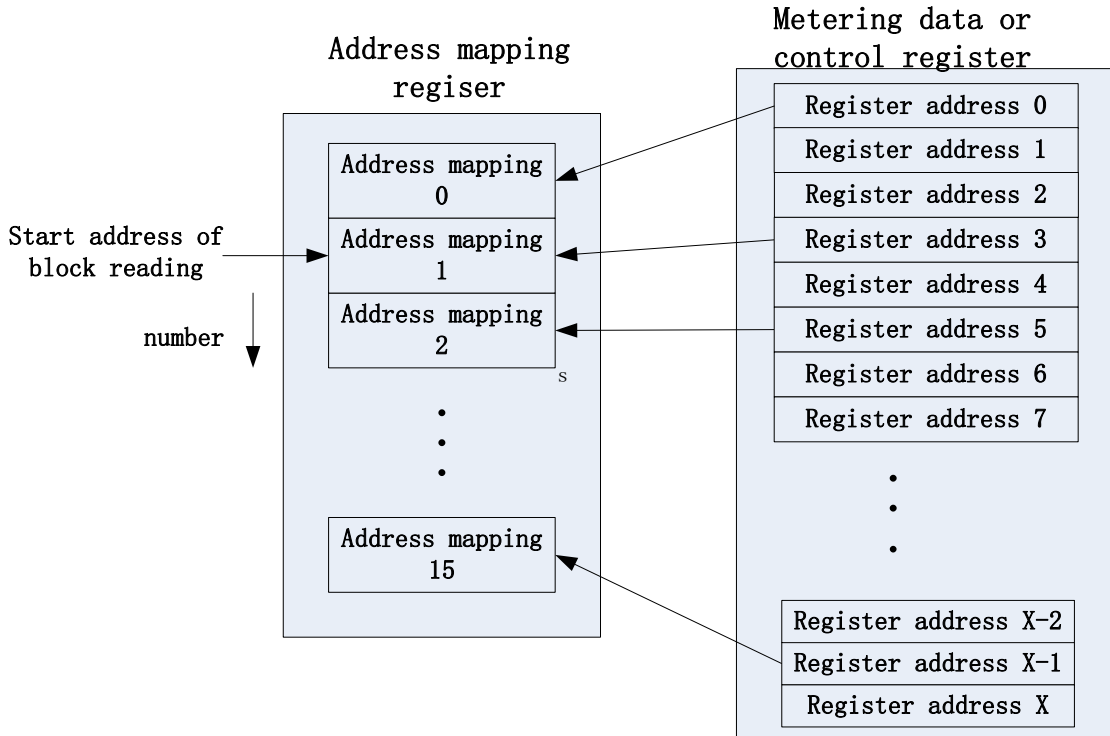

Feature:

- Support block reading operation by address mapping from 1~16 addresses that are not

consecutive.

- Device address {A1,A0} must be matched correctly.
- V93XX would be responded.

Figure18. Communication protocol for block reading operation

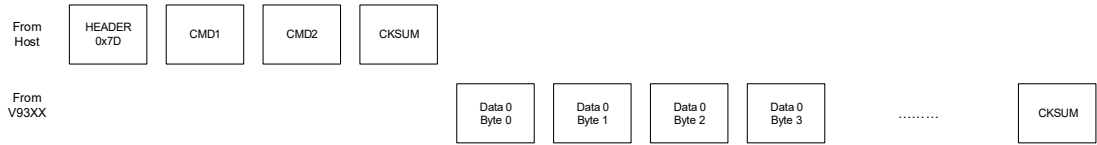

Table60. Structure of Data Byte (B7:B0) From Master MCU to V93XX on block reading Operation

Order	Byte	B7	B6	B5	B4	B3	B2	B1	B0
1	HEADER	0	1	1	1	1	1	0	1
2	CMD1	To select the data length on block reading operation 0: write 1 data of 32 bits 1: write 2 data of 32 bits ... 15: write 16 data of 32 bits				A1	A0	1	1
3	CMD2	X*	X*	X*	X*	To select the start address on block reading operation 16 block reading addresses are set by 4 registers of SYS_BLKX_ADDR For example: if N=4 (length is 5) and M=4(setting start address), it would start to read address from the bit7~0 of SYS_BLK1_ADDR register in the ADDR4. The 5 register addresses for block reading operation as below: 1: stored address ADDR4 in the Bit7~0 of the SYS_BLK1_ADD 2: stored address ADDR5 in the Bit15~8 of the SYS_BLK1_ADD 3: stored address ADDR6 in the Bit23~16 of the SYS_BLK1_ADD 4: stored address ADDR7 in the Bit31~24 of the SYS_BLK1_ADD 5: stored address ADDR8 in the Bit7~0 of the SYS_BLK2_ADD			

Order	Byte	B7	B6	B5	B4	B3	B2	B1	B0
4	CKSUM	Checksum. Add the above CMD1 and CMD2, invert the sum, and then add it to “0x33” to obtain the checksum. The equation is as below: CKSUM = 0x33 + ~ (CMD1 + CMD2)							
*X could be 0 or 1.									

Table61. Structure of Data Byte (B7:B0) From V93XX to Master MCU on block reading Operation

Order	Byte	B7	B6	B5	B4	B3	B2	B1	B0
1	Data 0 Byte 0	“Bit[7:0]” of the target data read from register (address ADDR _M)							
2	Data 0 Byte 1	“Bit[15:8]” of the target data read from register (address ADDR _M)							
3	Data 0 Byte 2	“Bit[23:16]” of the target data read from register (address ADDR _M)							
4	Data 0 Byte 3	“Bit[31:24]” of the target data read from register (address ADDR _M)							
...							
4xN+1	Data N Byte 0	“Bit[7:0]” of the target data read from register (address ADDR _{M+N})							
4xN+2	Data N Byte 1	“Bit[15:8]” of the target data read from register (address ADDR _{M+N})							
4xN+3	Data N Byte 2	“Bit[23:16]” of the target data read from register (address ADDR _{M+N})							
4xN+4	Data N Byte 3	“Bit[31:24]” of the target data read from register (address ADDR _{M+N})							
4xN+5	CKSUM	Checksum. Add the above 4×(N+1) target data bytes (Data 0~N Byte 0~3, comes from V93XX), CMD1, and CMD2(comes from MCU), invert the sum, and then add it to “0x33” to obtain the checksum. The equation is as below: CKSUM = 0x33 + ~ (CMD1 + CMD2 + Data 0 Byte 0 + Data 0 Byte 1 + Data 0 Byte 2 + Data 0 Byte 3 + + Data N Byte 0 + Data N Byte 1 + Data N Byte 2 + Data N Byte 3)							
If the length N equals to 0 on read operation, V93XX only sends 5 bytes of response frame to master MCU.									

8 SPI

8.1 Overview

V93XX supports two communication modes, UART and SPI, which can switch between SPI communication and UART communication without using external hardware jumper. After RSTN reset, RX reset or soft reset, V93XX uses UART communication by default. If you want to communicate by SPI, you must initialize the SPI interface once through the SPI protocol.

Support multi-machine communication mode, that is, when the output data port is idle, it is a high-resistance state. Through SPICSN chip selection signal support multiple V93XX to share a data bus.

The SPI interface of V93XX is a standard 4-wire or 3-wire SPI interface. 4-wire SPI mode must have a 50µs interval between every 2 read and write operations. 3-wire SPI mode has been low at chip select pin. When the V93XX sends command, the least significant byte and most significant bit always are shifted out firstly. The polarity and phase are 0.

When SPI reading register, the maximum speed can be 1/4 of system CLK; when reading RAM, the maximum speed can be 1/16 of system CLK. When the MCU reads the RAM or register of V93XX, if V93XX does not get the data in time, V93XX will send the wrong checksum byte to the MCU.

The RAM address range is 0x11~0x38, 0x43~0x54, 0x68, and 0x69. The remaining addresses are registers.

Before performing SPI read and write, it needs to write 0x5A7896B4 to the 0x7F addresses. If it does not do this, any SPI communication will be ignored.

When using SPI to access high 128 bit address registers (0x80 or above, including 0x80), it is necessary to write 0x4A985B67 to the 0x7F address using SPI. Afterwards, all address accesses will add a 128 offset to the originally given 7bit address. It is recommended to use SPI to configure addresses below 0x80 before configuring address registers above 0x80.

When writing 0x76B589A4 to the 0x7F address again, it means that the automatic address offset function is cancelled, and SPI can access addresses below 0x80.

SPI overtime mechanism: During communication, the time between the rising edges of every 2 SPCK needs to be shorter than 20ms, otherwise an SPI timeout is considered to occur.

Under the following conditions, an exception occurs in the SPI communication.

Table62. SPI communication errors

No	Condition	SPI_ERR set to	The condition for the
----	-----------	----------------	-----------------------

		1	next successful communication
1	SPI overtime (rising edge of every 2 SPCK needs to shorter than 20 ms).	Yes	No
2	4-wire SPI CLK error (not equals to 48 clocks).	Yes	No
3	V93XX reset happens.	No	Re-initialize SPI interface

8.2 Write Operation

After the write operation is completed, V93XX will not return a valid response to the MCU. It needs to read back the value of the register to confirm the success of the write operation.

Figure19. Communication protocol for SPI write operation

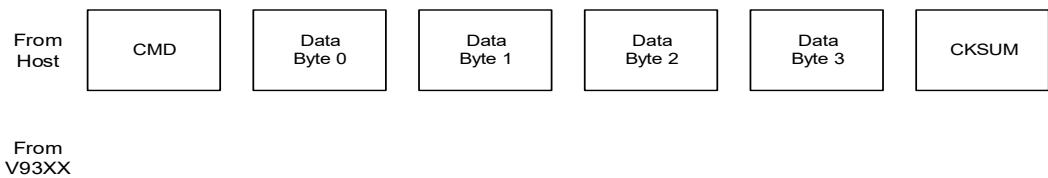

Table63. Structure of Data Byte (B7:B0) From Master MCU to V93XX on write Operation

Order	Byte	B7	B6	B5	B4	B3	B2	B1	B0	
1	CMD	Register address for write operation								0
2	Data Byte 0	"Bit[7:0]" of the target data write into register								
3	Data Byte 1	"Bit[15:8]" of the target data write into register								
4	Data Byte 2	"Bit[23:16]" of the target data write into register								
5	Data Byte 3	"Bit[31:24]" of the target data write into register								
6	CKSUM	Checksum 0. Add the above 5 target data bytes (Data Byte 0~3) and CMD1, invert the sum, and then add it to "0x33" to obtain the checksum. The equation is as below: $CKSUM = 0x33 + \sim(CMD + Data\ Byte\ 0 + Data\ Byte\ 1 + Data\ Byte\ 2 + Data\ Byte\ 3)$								

8.3 Read Operation

Figure20. Communication protocol for SPI read operation

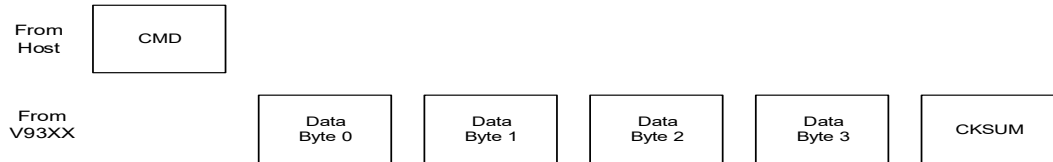

Table64. Structure of Data Byte (B7:B0) From Master MCU to V93XX on read Operation

Order	Byte	B7	B6	B5	B4	B3	B2	B1	B0
1	CMD	Register address for read operation							
2	-*	MCU generates 40 clocks is used for receiving 5 bytes of response frame sent back by V93XX. MCU sends any data has no effect on the operation.							
3	-*								
4	-*								
5	-*								
6	-*								
*- this byte could be any value									

Table65. Structure of Data Byte (B7:B0) From V93XX to Master MCU on read Operation

Order	Byte	B7	B6	B5	B4	B3	B2	B1	B0
1	-*	When the MCU sends a CMD to the V93XX, the data received by the MCU doesn't have to be concerned.							
2	Data Byte 0	"Bit[7:0]" of the target data read from register							
3	Data Byte 1	"Bit[15:8]" of the target data read from register							
4	Data Byte 2	"Bit[23:16]" of the target data read from register							
5	Data Byte 3	"Bit[31:24]" of the target data read from register							
6	CKSUM	Checksum. Add the above 4 target data bytes (Data Byte 0~3, comes from V93XX) and CMD1 (comes from MCU), invert the sum, and then add it to "0x33" to obtain the checksum. The equation is as below: CKSUM = 0x33 + ~(CMD + Data Byte 0 + Data Byte 1 + Data Byte 2 + Data Byte 3)							
*- this byte could be any value									

8.4 Initialize interface

The default communication interface of V93XX is UART. If it wants to initialize the SPI communication interface, it needs to write 0x5A7896B4 to the 0x7F address, that is, the MCU must send the following 6 bytes of data to V93XX via the SPI protocol.

Table66. SPI interface initialization data (hexadecimal)

CMD	Data Byte 0	Data Byte 1	Data Byte 2	Data Byte 3	CKSUM
0xFE	0xB4	0x96	0x78	0x5A	0x18

Because of the SPI write operation, V93XX will not send a valid response to the MCU. After writing 0x5A7896B4 to the 0x7F address to complete the SPI interface initialization, it cannot directly confirm whether the initialization is valid. It is recommended to read any readable register and check if the checksum byte is correct to confirm that the SPI interface initialization process is completed correctly.

After RSTN pin reset, RX reset, or global software reset occurs, the SPI interface is reset and the V93XX is restored to the UART communication interface. After that, the initialization process of SPI interface needs to be performed again before SPI read-write operation.

8.5 4-wire SPI Mode

- SPI interface initialization must be performed after RSTN pin reset, RX reset, or global software reset occurs on V93XX
- There must be a 50 μs (related to the accuracy of the system clock) interval between every 2 read or write operations
- The number of clocks per read or write must be 48
- Chip select pin must be pulled back high after each read or write operation

Figure21. Communication protocol for 4 wire SPI mode

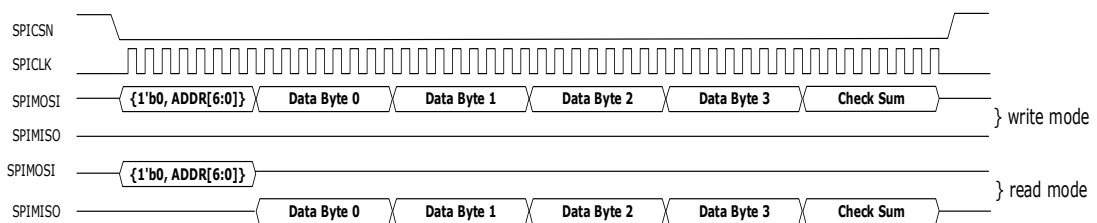

8.6 3-wire SPI Mode

- SPI interface initialization must be performed after RSTN pin reset, RX reset, or global

software reset occurs on V93XX

- Chip select pin is always low
- The number of clocks per read or write must be 48
- The clock pin must be pulled low for at least 400µs (related to the accuracy of the system clock) before each read or write operation

Figure22. Communication protocol for 3 wire SPI mode

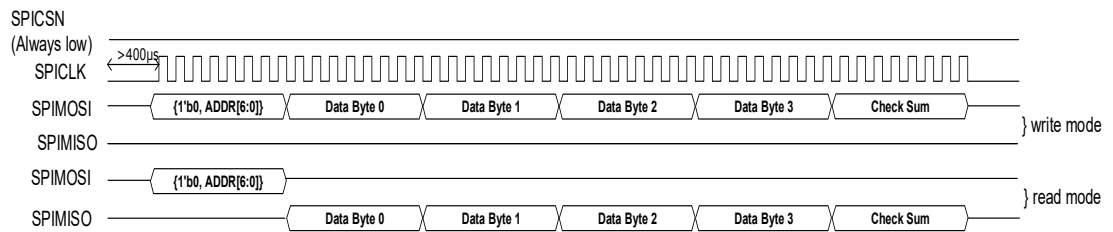

9 DSP

9.1 Overview

Metering DSP are mainly used in calculating total-wave active power, fundamental-wave active power, total/ fundamental-wave reactive power, total-wave apparent power, total-wave RMS and fundamental-wave RMS; also provides power grid events to detect and waveform storage functions.

The energy accumulator can flexible configuration, providing 2 high-speed energy accumulators and 6 low-speed energy accumulators.

Waveform data can output to external by DMA or internal storage.

9.2 Features

- Support 1 voltage channel and 2 current channels metering at the same time
- Selectable the full-wave bandwidth
- Provide 2 configurable fundamental-wave channels which can calculate power and RMS of fundamental-wave.
- Selectable refresh time for average power value or average RMS.
- Provide the average RMS of 10 or 12 cycles which used in voltage flicker detection.
- Support to determine the power-creep, voltage swell or dip, over or under-voltage and over or under-current.

9.3 Functional Diagram

Figure23. Functional Diagram 1 of Metering DSP

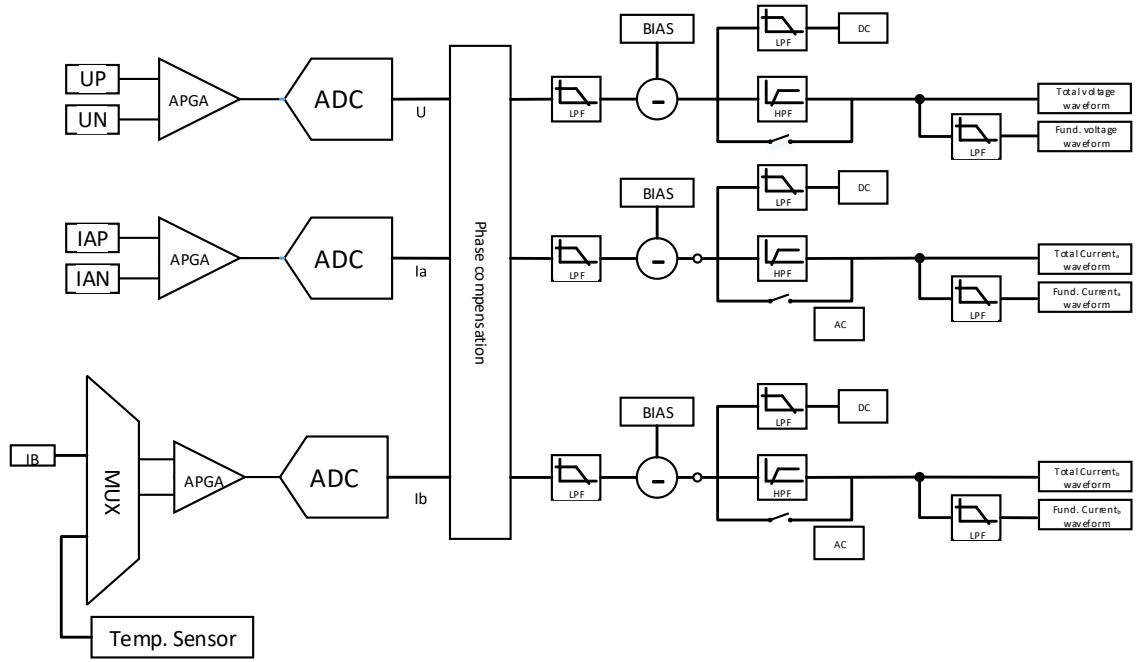
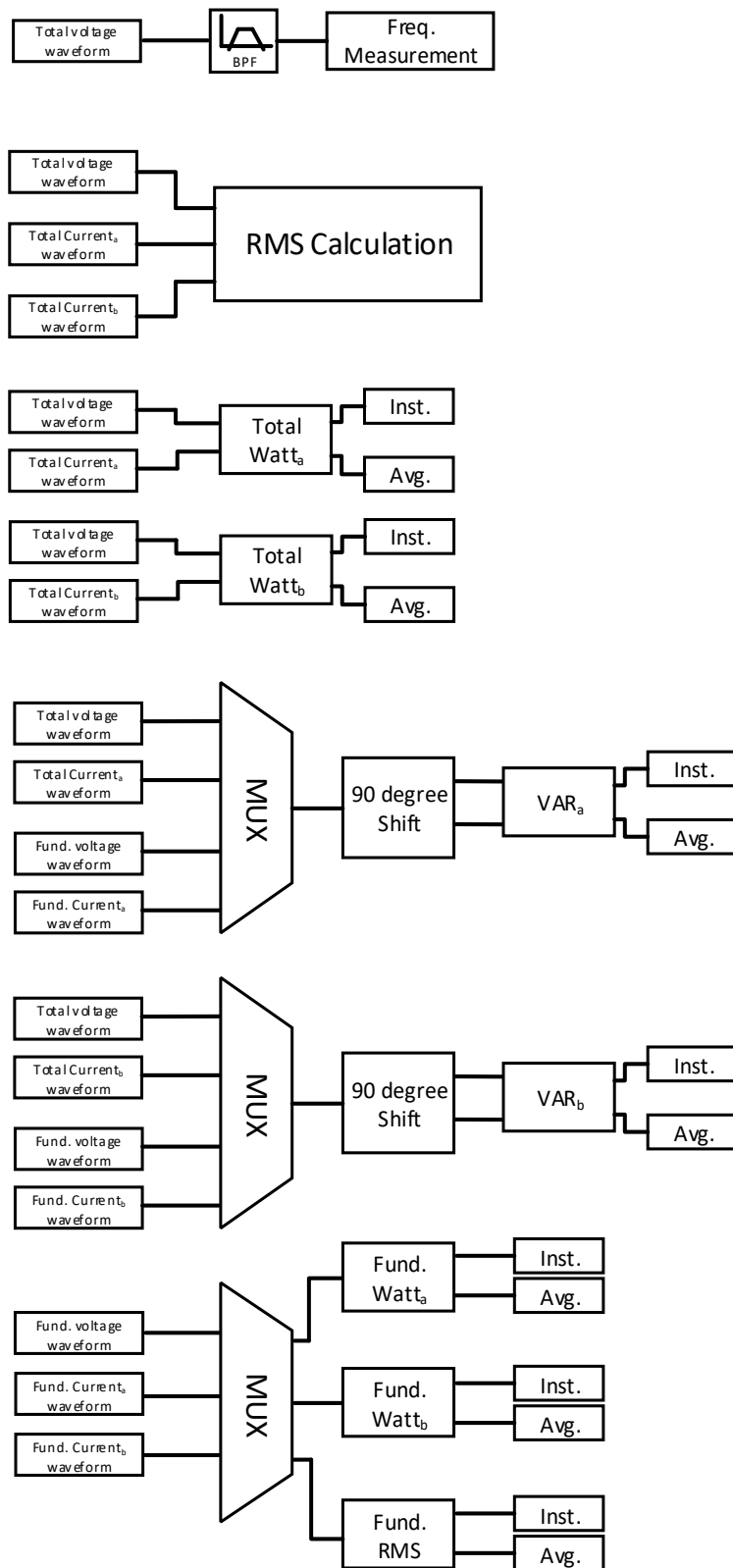

Figure24. Functional Diagram 2 of Metering DSP



9.4 Analog Inputs

The V93XX supports two types of current signal inputs. Among them, the input current of the current sensor (CT, Current Transformer) adopts a fully differential input method with double terminals, which requires a total of four ports. The wiring method is shown in the figure below (taking AGND as the common-mode voltage, and the common-mode voltage can also be in other forms). IP and IN are the differential input pins of the current channel. The four ports are IAP and IAN of the current channel IA, as well as IBP and IBN of the current channel IB.

Figure25. CT for Current Analog Input

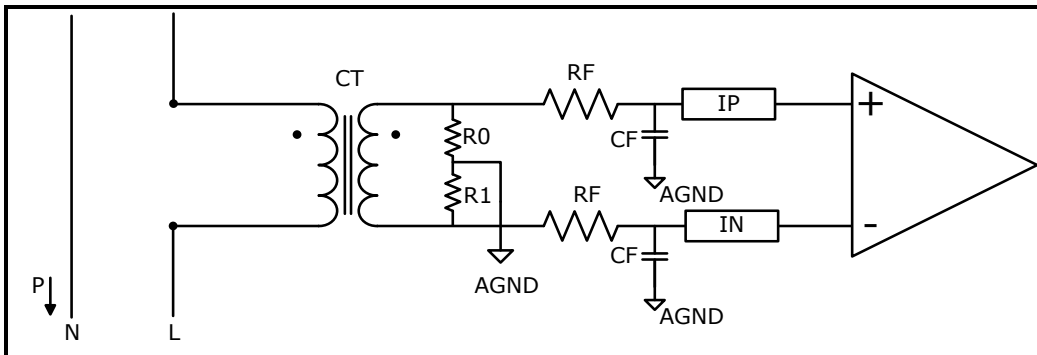

Manganese copper resistance can also be used to shunt the network input current, and AGND can be used for grounding.

Figure26. Shunt Resistor Network for Current Analog Input

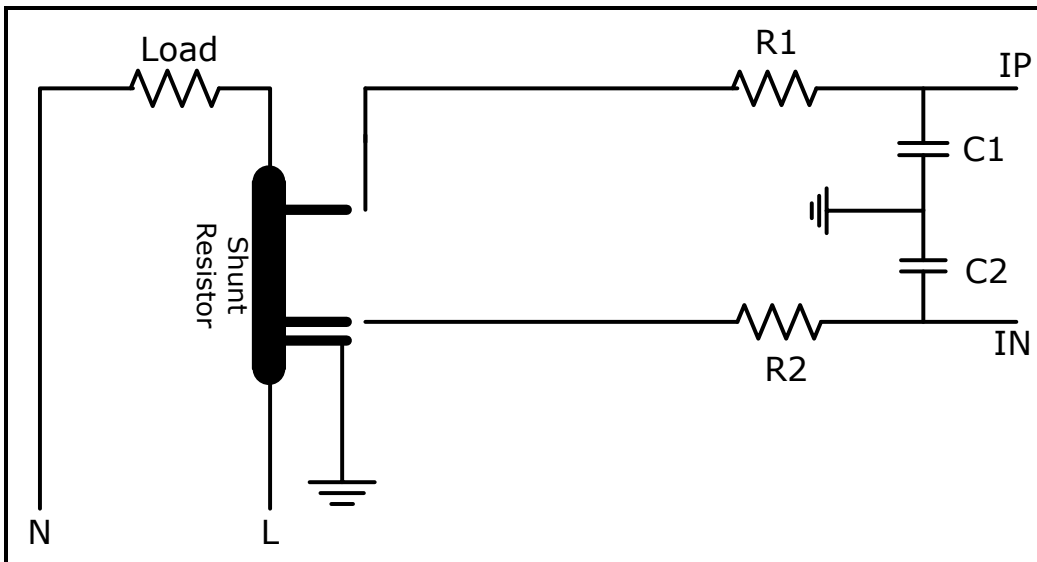

V93XX supports 1 circuit of voltage signal input. The pseudo differential input mode is adopted for voltage. Compared with the UN grounding, UP is a positive terminal, which requires two ports in total. The following are two typical connection methods of voltage channel, voltage transformer mode and resistance voltage division mode.

Figure27. Analog Input of Voltage

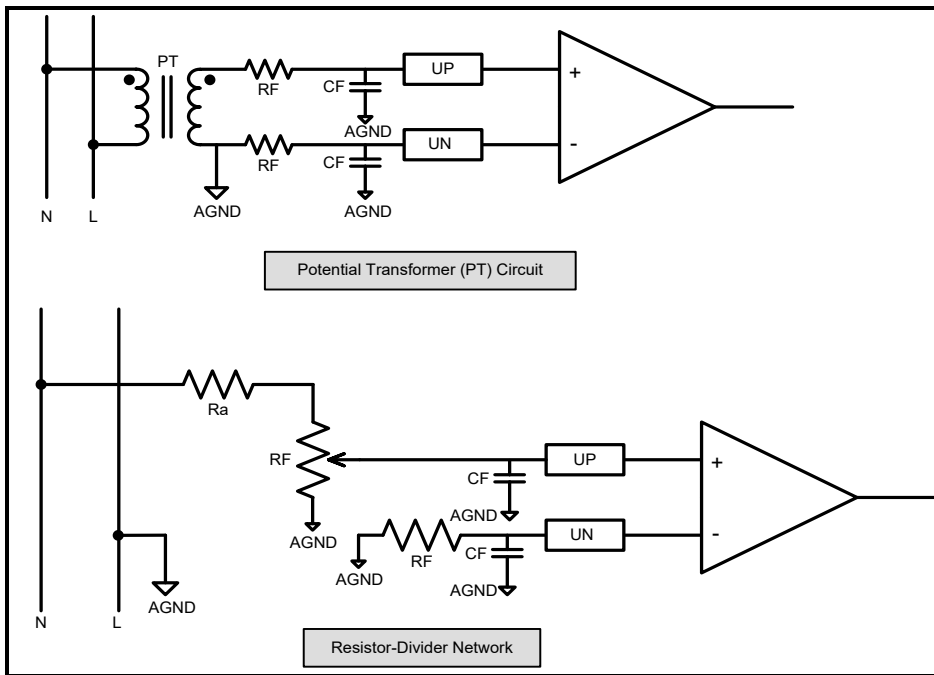

The full measurement scale of ADCs is ± 1.1 V. To match the output signal of the sensors with the measurement scale of ADCs, groups of Analog Programmable Gain Amplifiers (APGA) are set. The product of the analog input and the set APGA should not be over ± 1.1 V.

Figure28. Current/voltage channel analog gain configuration

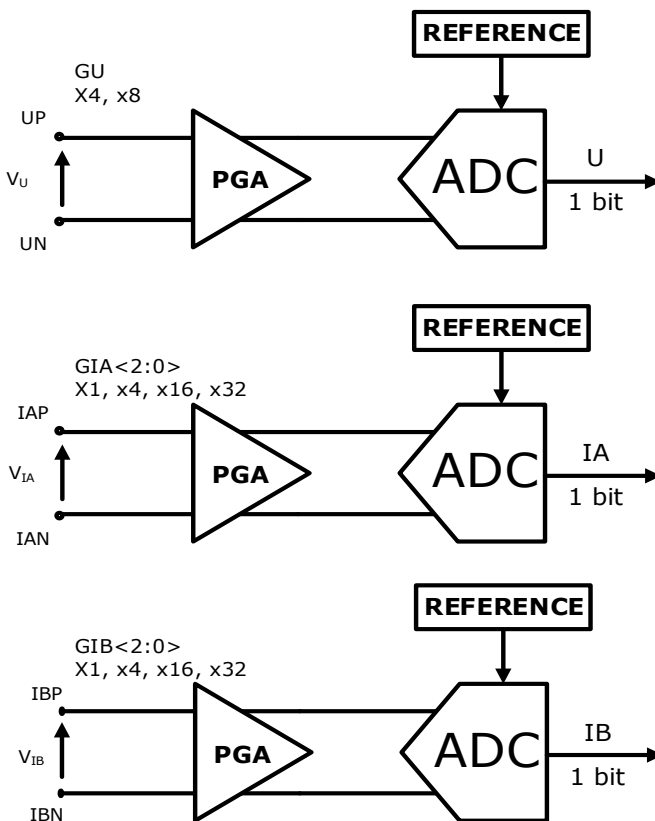

Table67. Analog PGA Gain Configuration for Current and Voltage Analog Input

Register	Bit	Default	Description
ANA_CTRL1 Register	Bit[14:12] GIB<2:0>	0	To adjust the gain of current ADC in the channel B. 000: 4 001: 1 010: 32 011: 16 100/101/110/111: prohibited GIB[2:0] is recommended set to 000 for proper operation.
	Bit11 GU	0	To adjust the gain of voltage ADC. 0: 8 1: 4 This bit must be set to 0 for proper operation.
	Bit[10:8] GIA<2:0>	0	To adjust the gain of current ADC in the channel A. 000: 32 001: 16 010: 4 011: 1 100~111: prohibited GIA[2: 0] is recommended set to 000 for proper operation.

9.5 Analog-to-Digital Conversion

Second-order Σ - Δ ADCs are designed in three channels of V93XX for analog-to-digital conversion, and their full measurement scale is ± 1.1 V. By default, Σ - Δ ADCs are disabled. Users can turn on or off the ADC of each channel through ADCUEN, ADCIBEN and ADCIAEN (metering control register 0 (0x02, DSP_CTRL0)). It should be noted that ADC and digital processing of each channel use the same control bit, so they are turned on and off at the same time.

Table68. Enable/Disable ADCs

Register	Bit	Default	Description
DSP_CTRL0 Register	Bit2 ADCUEN	0	To enable the voltage channel (including ADC and DSP).
	Bit1 ADCIBEN	0	To enable the current channel B (including ADC and DSP).



Register	Bit	Default	Description
	Bit0 ADCIAEN	0	To enable the current channel A (including ADC and DSP).

9.6 Phase Compensation

Figure29. Phase Compensation Schematics

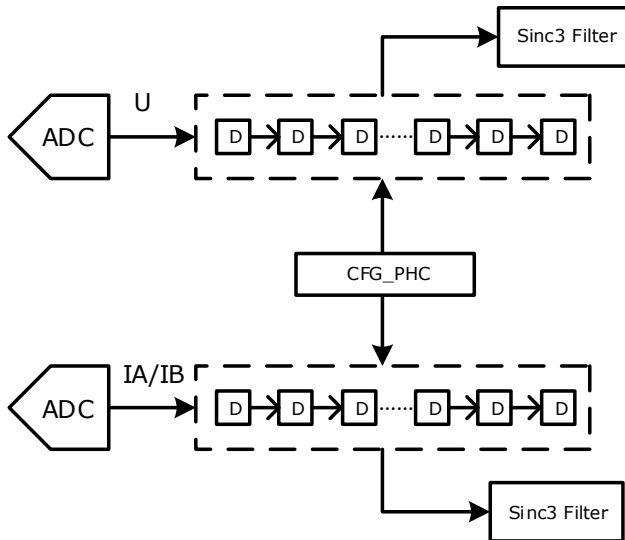

A phase compensation circuit composed of a time delay chain of fixed length is applied to correct the phase angle error via delaying the selected signal. Either current or voltage signals can be delayed.

By default phase compensation is disabled. Users can enable this function via configuring DSP_CFG_PHC (Phase Measurement Register). If the register value is non-zero, turn on phase compensation automatically. When phase compensation is enabled, the phase angle error between I1 and U, and I2 and U, are corrected respectively.

In 50-Hz power grid, when the sampling frequency of the phase compensation circuit (f_{smp1}) is 3.2768 MHz, the calibration resolution is 0.0055°/lsb, and the maximum phase angle error to be corrected is $\pm 4.21875^\circ$. The value of f_{smp1} is determined by the configuration of bits “DSP_MODE <3:0>” (DSP_CTRL0 Register).

At a lower power factor (PF), the phase angle error can cause greater energy metering error. So generally, the phase angle error is calibrated at PF=0.5L to ensure the metering accuracy. When PF=0.5L, users can use a simple equation as follows to calculate the value N.

Table69. f_{smp1} Determines Phase Compensation Resolution and Correction Range

DSP_MODE	f_{smp1}	calibration_accuracy	Calibration_range
----------	------------	----------------------	-------------------

		(degree)	(degree)
0x00, 0x01, 0x02	6.5536MHz	0.005493164	±4.21875
0x06, 0x07	3.2768MHz	0.010986328	±8.4375
0x08	819.2KHz	0.021972656	±16.855

Table70. Registers for Phase Compensation

Register	Bit	Default	Description
Phase Calibration Register	Bit[26:16] CFG_PHCB	0	Phase Error Calibration Register. The register needs to be configuration verification and self-checking. phase error calibration value for channel B; Where the range is from -766 to 767.
	Bit[10:0] CFG_PHCA	0	Phase Error Calibration Register. The register needs to be configuration verification and self-checking. phase error calibration value for channel A; Where the range is from -766 to 767.

9.7 Generation of raw waveform data

In V93XX, decimation filters are designed to reduce the noise of the 1-bit code stream output from the oversampling Σ/Δ ADC and to reduce the sampling frequency to 1/256 of f_{ADC} .

Figure30. Generation of raw waveform data

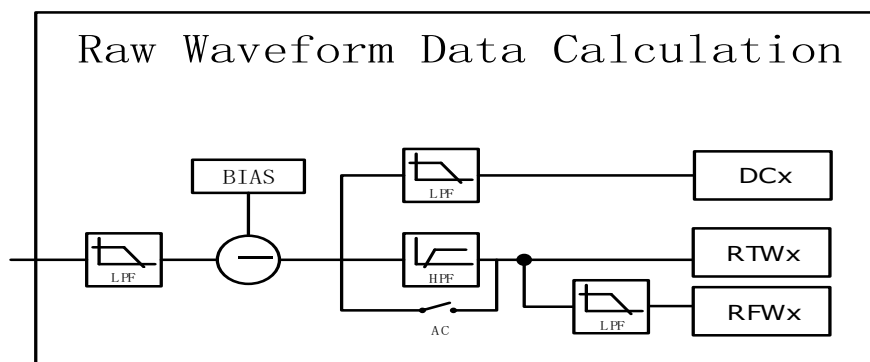

Each ADC channel can generate DC raw instantaneous data, full wave AC raw instantaneous data and fundamental wave AC raw instantaneous data.

When configuring DC_METER_MODE (DSP_CTRL0 Register) is 1, DC metering can be supported.

The user can turn on or off the ADC of each channel through ADCUEN, ADCIBEN and ADCIAEN

(DSP_CTRL0 Register). It should be noted that ADC and digital processing of each channel use the same control bit, so they are turned on and off at the same time.

Table71. Enable/Disable Digital Inputs

Register	Bit	Default	Description
DSP_CTRL0 Register	Bit2 ADCUEN	0	To enable the voltage channel (including ADC and DSP).
	Bit1 ADCIBEN	0	To enable the current channel B (including ADC and DSP).
	Bit0 ADCIAEN	0	To enable the current channel A (including ADC and DSP).

As depicted in the above figure, the signal output from the decimation filter in each channel will be sent to a high-pass filter (HPF) to remove the DC components introduced by the sensors and ADCs. In the V93XX, this high-pass filter can be disabled. When users want faster response time, they can bypass the high pass filter.

Digital programmable gain amplifiers (DPGA) with possible gain selection via PGA_U (DSP_CTRL1 Register) is applied to U channel digital signals output from the high-pass filters to amplify its capability of depressing truncation noise when a low signal was input. Please note the product of the analog input and the total PGA gains, including APGA and DPGA, should not be over the measurement scales of the ADCs.

Table72. DPGA Gain Selection for Digital Signals

Register	Bit	Default	Description
DSP_CTRL1 Register	Bit21 PGA_U	0	Voltage channel digital PGA: 0: X1 1: X4

9.8 RMS Calculation and Calibration

The V93XX supports RMS calculation.

As illustrated in Figure31, the current or voltage raw waveform signal is multiplied with itself in the multiplier to get the product with the second harmonic which can be removed by the low-pass filter, and then the signal processed output from the low-pass filter, is offset corrected to remove noise. Then it is sent to the circuit for rooting processing that produces a 32-bit datum, the raw RMS value of current or voltage. The raw RMS data will be gain calibrated and then stored in instantaneous RMS registers. Besides, the instantaneous RMS data will be averaged to acquire the average RMS data that are stored in average RMS registers.

Figure31. RMS Calculation and Calibration

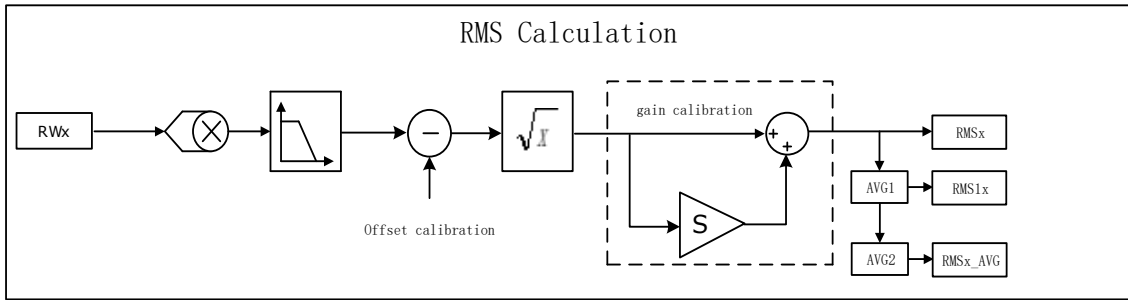

The content of all the instantaneous and average RMS data registers are in the form of 32-bit 2'-complement. When RX reset, global software reset occurs, these registers are reset to their default states.

9.9 Active Power Calculation and Calibration

Figure32. Signal Processing for Active Power Calculation and Calibration

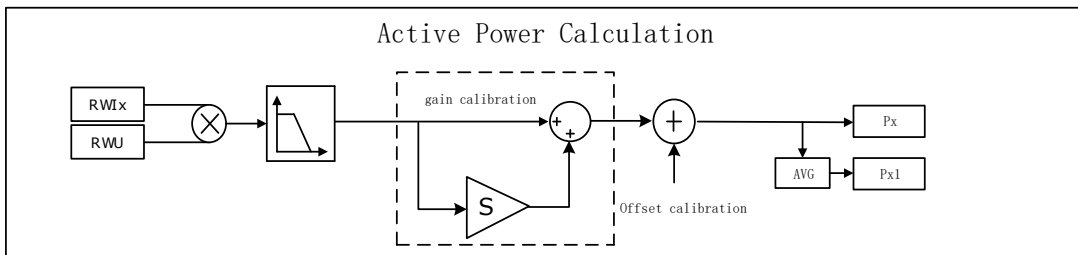

The current and voltage raw waveform current signal multiply each other. Then, the product is input to the low-pass filter (LPF) to remove the harmonics and the ripples caused by the noise, and the output of the LPF is the raw active power. This raw power is gain calibrated and then offset calibrated to acquire the instantaneous active power. The instantaneous active power will be averaged to get the average active power. The content of all the registers are in the form of 32-bit 2'-complement, and they will be reset to their default states When RX reset, global software reset occurs.

The active power data PA or PB after the ratio difference correction will be averaged and stored in PA1 or PB1 power average registers.

9.10 Reactive Power and Calibration

Figure33. Signal Processing for Reactive Power Calculation and Calibration

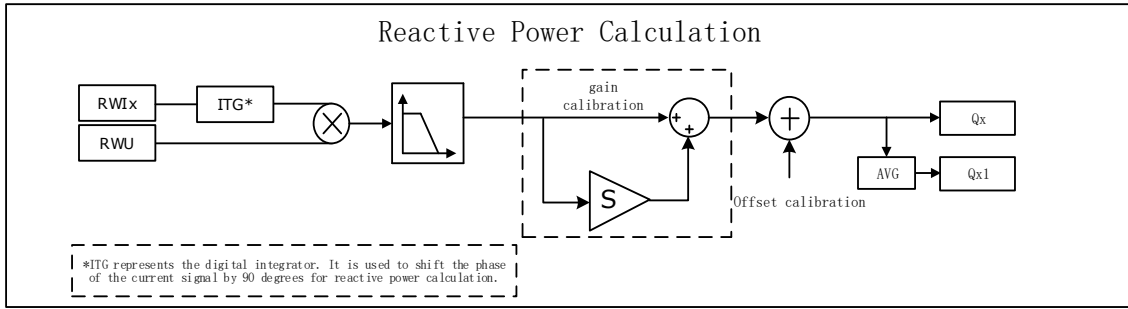

The original current waveform signal is multiplied by the original voltage waveform signal after 90 ° phase adjustment by Hilbert filter. Then, the product is input to the low-pass filter (LPF) to remove the harmonics and the ripples caused by the noise, and the output of the LPF is the raw reactive power. This raw power is gain calibrated and then offset calibrated to acquire the instantaneous reactive power. The instantaneous reactive power will be averaged to get the average reactive power. The content of all the registers are in the form of 32-bit 2'-complement, and they will be reset to their default states When RX reset, global software reset occurs.

The reactive power data QA or QB after the ratio difference correction will be averaged and stored in QA1 or QB1 power average registers.

Reactive power comes from full wave data and fundamental wave data, users can select by QB_MODE and QA_MODE selection (metering control register 0 (0x02, DSP_CTRL0).

Table73. Reactive power Selection

Register	Bit	Default	Description
Metering Control Register 0 (0x02, DSP_CTRL0)	Bit19 QB_MODE	0	To select mode for Reactive power B. 0: total wave, reactive power 1: fundamental wave, reactive power
	Bit18 QA_MODE	0	To select mode for Reactive power A. 0: total wave, reactive power 1: fundamental wave, reactive power

9.11 Apparent Power Calculation

Figure34. Apparent Power Calculation

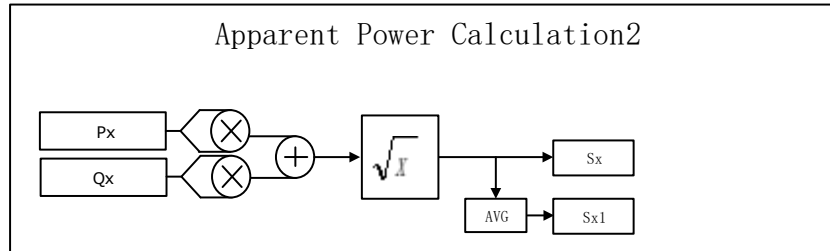
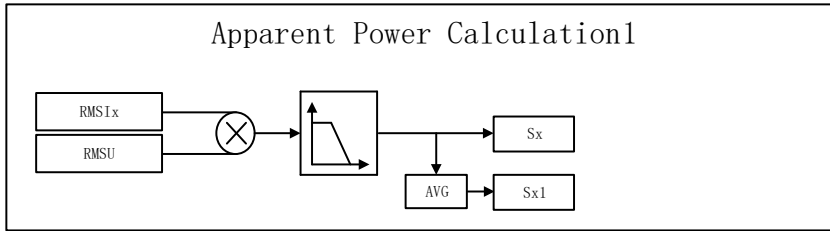

The V93XX supports apparent power calculation. There are two calculation methods for apparent power: calculation by RMS value and calculation by power value.

In the V93XX, the instantaneous current and voltage RMS are multiplied to acquire the apparent power, as described in the following equation:

$$S = I_{rms} \times U_{rms} \tag{Equation 1}$$

Where, S represents apparent power;

I_{rms} and *U_{rms}* are the average current and voltage RMS.

In the V93XX, the apparent power is obtained by square root of the sum of the square of the instantaneous active power and the square of the instantaneous reactive power, as described in the following equation:

$$S = \sqrt{P^2 + Q^2} \tag{Equation 2}$$

Where, S is the apparent power;

P is the instantaneous active power value;

Q is the instantaneous reactive power value.

The content of the apparent power registers are in the form of 32-bit 2'-complement. When RX reset, global software reset occurs, these registers are reset to their default states.

9.12 Apparent Power Calculation

Register	Bit	Default	Description
DSP_CTRL0 Register	Bit24 S_MODE	0	Source select for Apparent power calculation. 0: by RMS value 1: by power value

9.13 Power-creep Detection

Active power, reactive power, and apparent power support the power-creep function. See Power-creep Threshold Register. When the instantaneous active power/reactive power/apparent power of the channel A and the channel B are higher than the upper threshold for three consecutive times, the startup state is entered. When the instantaneous active power/reactive power/apparent power of the channel A and the channel B are lower than the upper threshold for three consecutive times, the power-creep state is entered.

The user can check whether the instantaneous active power/reactive power/apparent power is in the power-creep state by Bit17~Bit12 of the SYS_STS system status register description (0x74, SYS_STS).

Table74. Power-creep Detection Description

Register	Bit	Default	Description
DSP_CTRL1 Register	Bit1 PWR_CRP_EN	0	To determine the power of power-creep. The power-creep determination uses continuous 3 average and threshold compare. If lower the threshold, then here will be the power-creep status. 0: disable the power-creep detection 1: enable the power-creep detection
SYS_STS Register	Bit17 SBCREEP	0	Status bit for power-creep detection for reactive power Channel B. 0: start 1: power-creep
	Bit16 QBCREEP	0	Status bit for power-creep detection for active power Channel B. 0: start 1: power-creep

Register	Bit	Default	Description
	Bit15 PBCREEP	0	Status bit for power-creep detection for active power Channel A. 0: start 1: power-creep
	Bit14 SACREEP	0	Status bit for power-creep detection for reactive power Channel A. 0: start 1: power-creep
	Bit13 QACREEP	0	Status bit for power-creep detection for active power Channel A. 0: start 1: power-creep
	Bit12 PACREEP	0	Status bit for power-creep detection for active power Channel B. 0: start 1: power-creep

Table75. Power-creep Threshold Register

Address	Register	R/W	Data Format	Description
0x55	DSP_OV_THL	R/W	32-bit Complement Code	To set the lower threshold for the power creep detection for instantaneous active power/ reactive power/ apparent power of channel A and B.
0x56	DSP_OV_THH	R/W	32-bit Complement Code	To set the upper threshold for the power creep detection for instantaneous active power/ reactive power/ apparent power of channel A and B.

9.14 Frequency measurement

Figure35. Frequency measurement

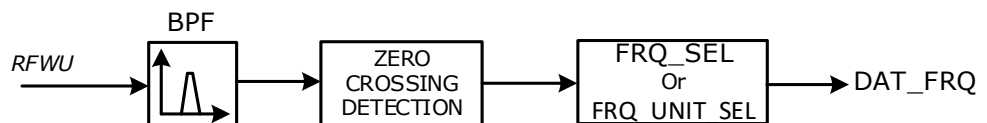

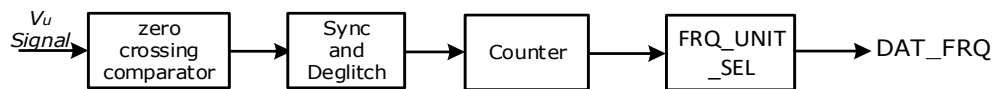

V93XX supports frequency measurement, which is stored in the grid frequency register (0x21, DSP_DAT_FRQ). Supports digital mode frequency measurement and analog mode frequency measurement, by configuring the FRQ_ANA_ON of the metering control register 6 (0x80, DSP_CTRL6) selects the measurement mode.

The principle of digital mode frequency measurement is to filter the original fundamental waveform signal of the voltage through a bandpass filter with a center frequency of 50Hz (which has a 25dB attenuation at 150Hz), and then perform zero crossing detection on the filtered output signal. After wave_cnt signal cycles of averaging, the frequency measurement result is output. The resolution of line voltage frequency measurement can reach 0.05Hz/lb. Users need to configure the bandpass filter coefficient according to different DSP_MODE (Metering Control Register 0 (0x02, DSP_CTRL0)). For details, please refer to the bandpass filter coefficient register (Bandpass Filter Register (0x37, DSP_CFG_BPF)).

The principle of frequency measurement in analog mode is to obtain a square wave that is consistent with the frequency of the waveform to be measured by inputting the original analog signal into the analog zero crossing comparator, then synchronously deglitch it, and counting it through the system clock to obtain the frequency value. This measurement method has higher accuracy, and the frequency accuracy depends on the system clock. The maximum error in the counting result is 1 system clock cycle.

The user accumulates the number of cycles and the frequency constant through the metering control register 0 (0x02, DSP_CTRL0) and the metering control register 6 (0x80, DSP_CTRL6).

Table76. Frequency measurement configure register

Register	Bit	Default	Description
metering control register 0 (0x02, DSP_CTRL0)	Bit[29:28] FRQ_SEL	0	Source comes from the register value of DSP_DAT_FRQ. 00: accumulation value for line frequency test value of 16 cycles (the default update time is 320ms) 01: line frequency test value of 1 cycle (the default update time is 20ms) 10: line frequency test value of 64 cycles (the default update time is 1280ms) 11: Reserved

metering control register 6 (0x80, DSP_CTRL6)	Bit17 FRQ_ANA_ON	0	Frequency measurement mode switch 0: Off. The original digital frequency measurement method will be used by default 1: On, when enabled, the method of sampling and simulating frequency measurement will be used
	Bit16 FRQ_UNIT_ON	0	Digital measurement frequency unit determines switch 0: Still managed by FRQ_SEL determines the measurement unit 1: By FRQ_UNIT_SEL determines the unit of measurement frequency This switch only applies to the selection of digital measurement frequency average period, and has no effect on the selection of analog measurement frequency average period
	Bit[15:12] FRQ_UNIT_SEL	0	Digital/Analog Measurement Frequency Average Period Selection 0: 1 cycle average frequency 1: Average frequency of 2 cycles ... 15: Average frequency of 16 cycles

$$f = \text{wave_cnt} * \text{freq_const} / \text{DSP_DAT_FRQ}$$

Where,

f: Signal frequency, Hz;

wave_cnt: number of cycles;

freq_const: frequency constant, Hz;

DSP_DAT_FRQ: The value of the frequency value register (in decimal). The value of the frequency value register is a 16 bit unsigned positive number.

When configuring the frequency control register (0x80, DSP_CTRL6) and selecting the method of analog measurement frequency, the average frequency of the specified period can be selected through configuration and stored in the power grid frequency register. The calculation formula is the same as the above power grid frequency, where wave_cnt needs to be replaced with the unit of the specified cycle, such as configuring the average frequency of 4 cycles, then wave_cnt=4.

Table77. Frequency register source FRQ_SEL and DSP_CTRL6 Relationship description

FRQ_ANA_ON	FRQ_UNIT_ON	FRQ_SEL	FRQ_UNIT_SEL	wave_cnt
0	0	0	*	16
0	0	1	*	1
0	0	2	*	64
0	1	*	0	1
0	1	*	1	2
0	1	*	2	3
0	1	*	3	4
0	1	*	4	5
0	1	*	5	6
0	1	*	6	7
...
0	1	*	15	16
1	*	*	0	1
1	*	*	1	2
1	*	*	2	3
1	*	*	3	4
1	*	*	4	5
1	*	*	5	6
1	*	*	6	7
...
1	*	*	15	16

Table78. Frequency Constant Description

DSP_MODE	FRQ_ANA_ON	freq_const
0x08	0	1600
0x06, 0x07	0	3200
0x0, 0x01, 0x02	0	6400
0x08	1	1638400
0x06, 0x07	1	3227800
0x0, 0x01, 0x02	1	6553600

9.15 Phase measurement

V93XX supports voltage phase and current phase measurement. The operation principle is, write 1 to the register DSP_PHS_STT (0x61) to start phase measurement. It starts counting at a

certain frequency, until zero-crossing events happened, it stops counting. This counting value will write into the voltage phase register or current phase register. It also records two sampling values before and after the zero-crossing. User can obtain better accurate phase value by interpolation method.

The certain frequency: When DSP_MODE is 0, 1, 2, the sampling frequency of voltage signal used for phase testing is 6.4 KHz. When DSP_MODE is 6 and 7, the sampling frequency of voltage signal used for phase testing is 3.2 KHz.

Current phase measurement only supports IA channel or IB channel at one time, which can be configured. The channel selection is consistent with the current zero crossing input source. Current zero crossing input source through PHSI_SEL (metering control register 1 (0x03, DSP_CTRL1)) selects IA channel or IB channel. Zero crossing event detection mode can be realized through SIGN_SEL (metering control register 1 (0x03, DSP_CTRL1)) selects negative zero crossing or positive zero crossing.

Table79. Frequency Constant Description

Register	Bit	Default	Description
DSP_CTRL1 Register	Bit20 PHSI_SEL	0	To select the input source for current zero-crossing. 0: current channel IA 1: current channel IB
	Bit[19:18] SIGN_SEL	0	To select the detect method of zero-crossing: 0: negative direction (it indicates the signal changing from positive to negative is occurring a zero-crossing event) 1: positive direction (it indicates the signal changing from negative to positive is occurring a zero-crossing event) 2: positive and negative direction 3: disable the zero-crossing detection function

9.16 Calibration

Please refer to “V93xx series sample meter calibration method-application note V1.4(EN)”.

10 Active Waveform upload and buffer

V93XX waveform data can be transferred through DMA, or stored locally through waveform buffer. Trigger mode supports command trigger and event trigger.

10.1 Active Waveform upload

10.1.1 Overview

The V93XX supports the DMA mode for data transmission and sends up to 3 original waveform data to the external MCU through the SPI interface host mode. The user can set the active waveform upload through the metering control register 5 (0x07, DSP_CTRL5), and configure the active waveform data upload IO port P0~P6 through IO configuration register 0 (0x7D, SYS_IOCFG0) and IO configuration register 1 (0x7E, SYS_IOCFG1).

The number of sampling points per cycle of the DMA transmission data is related to DSP_MODE (Bit[7:4]) of DSP_CTRL0 (Metering Control Register 0 (0x02, DSP_CTRL0)); the number of channels is related to Bit10~8 of DSP_CTRL5 (0x07, DSP_CTRL5). Its relationship is shown in the following table:

When Bit [31] of DSP_CTRL6 is disable, the number of sampling points per cycle sent by DMA and the DSP_MODE (Bit [7:4]) of the metering control register 0 (0x02, DSP_CTRL0) is the same number of points, when after the bit [31] of DSP_CTRL6 is enable, the number of points actively uploaded is the corresponding multiple of the number of points in the DSP_MODE; The number of channels is related to Bit10~8 of the metering control register 5 (0x07, DSP_CTRL5). The relationship is shown in the table below:

Table80. Active waveform data upload configuration

DSP_MODE	DSP_CTRL5 Bit10~8	DSP_CTRL6 [31:29]	Channel number	Sampling points	SPI CLK Frequency
0/10~15	111	000	3	128	819.2KHz
0/10~15	111	100	3	128	819.2KHz
0/10~15	111	101	3	64	819.2KHz
0/10~15	111	110	3	32	819.2KHz
0/10~15	011/101/110	000	2	128	819.2KHz
0/10~15	011/101/110	100	2	128	819.2KHz
0/10~15	011/101/110	101	2	64	819.2KHz
0/10~15	011/101/110	110	2	32	819.2KHz
0/10~15	001/010/100	000	1	128	409.6KHz
0/10~15	001/010/100	100	1	128	409.6KHz

0/10~15	001/010/100	101	1	64	409.6KHz
0/10~15	001/010/100	110	1	32	409.6KHz
1/6	111	000	3	64	409.6KHz
1/6	111	100	3	64	409.6KHz
1/6	111	101	3	32	409.6KHz
1/6	011/101/110	000	2	64	409.6KHz
1/6	011/101/110	100	2	64	409.6KHz
1/6	011/101/110	101	2	32	409.6KHz
1/6	001/010/100	000	1	64	204.8KHz
1/6	001/010/100	100	1	64	204.8KHz
1/6	001/010/100	101	1	32	204.8KHz
2/7	001~111	000	1、2、3	32	204.8KHz

10.1.2 Timing and Format

The V93XX transmits the original waveform of the signal to the peripheral device via the DMA SPI interface. The SPI polarity and phase are configurable. When the polarity is 0 and the phase is 0, the transmission timing is as follows:

Figure36. Communication timing of DMA SPI

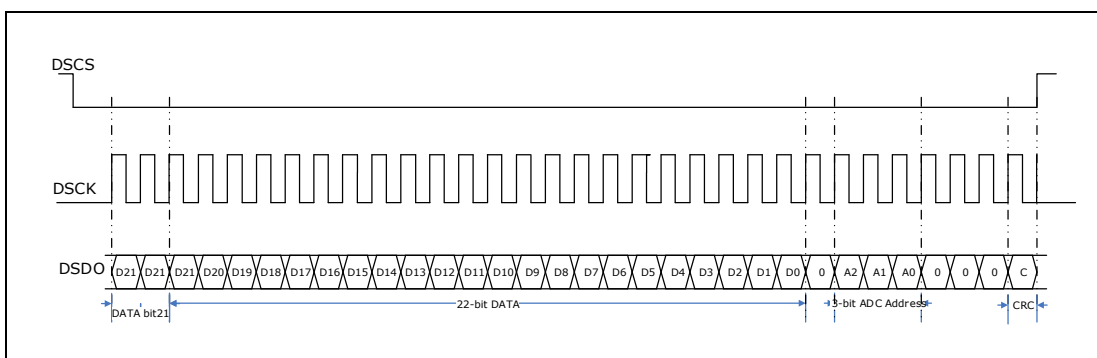

Transmission mode: The transmission of 32-bit data is completed at one time. The format of the data frame for each transmission is as follows:

Table81. Active waveform data upload format

Bit	Contents
31:30	Same as Bit29.
29:8	The original waveform of 22-bit for each channel ADC signal source.
7	0
6	Indicates whether the present waveform data is from a voltage channel. 0: no 1: yes

5	Indicates whether the present waveform data is from a channel IA. 0: no 1: yes
4	Indicates whether the present waveform data is from a channel IB 0: no 1: yes
3:1	000
0	Odd parity bit. The check range is the forward 31bit.

10.2 Waveform Buffer

After the waveform buffer function is enabled, the waveform data is stored in the RAM, supporting single-channel waveform data storage and dual-channel waveform data simultaneous storage mode. If the waveform buffer of three channels is enabled at the same time, the channel IB is invalid. The user can configure the waveform buffer and start and end condition selection by metering control register 5 (0x07, DSP_CTRL5), When the Bit [31] of DSP_CTRL6 is disable, the number of sampling points per cycle in the waveform buffer is the same from the DSP_MODE (Bit [7:4]) of the metering control register 0 (0x02, DSP_CTRL0), when After Bit [31] of DSP_CTRL6 is enable, the number of waveform buffer points is the corresponding multiple of the number of points in DSP_MODE. After the waveform buffer configuration is completed, the user can check whether the waveform buffer is completed by the WAVE_STORE of the system interrupt status register (0x72, SYS_INTSTS). After completion, the user can obtain waveform buffer data by repeatedly reading the waveform data register (0x69, DAT_WAVE), and it can read up to 309 data every time.

Table82. waveform buffer data format

channel	High 16Bit	Low 16Bit
IA	IADATA _{2n+1}	IADATA _{2n}
IB	IBDATA _{2n+1}	IBDATA _{2n}
U	UDATA _{2n+1}	UDATA _{2n}
IA+IB	IBDATA _n	IADATA _n
IA+U	IADATA _n	UDATA _n
IB+U	IBDATA _n	UDATA _n
IA+IB+U (the channel IB is invalid at this time)	IADATA _n	UDATA _n

Where the range of n is 0~308

11 Electrical Signal monitoring

11.1

11.2 Zero-crossing Detection

The V93XX supports zero-crossing detection for voltage channel and current channel (the zero-crossing channel can be selected as the channel IA or channel IB by Bit20 of Metering Control Register 1 (Metering Control Register 2 (0x03, DSP_CTRL1)). The zero-crossing direction can be selected by Bit19~Bit18 of the metering control register 1 (0x03, DSP_CTRL1). When the voltage/current channel signal has a zero-crossing event, the voltage zero-crossing flag USIGN/current zero-crossing flag ISIGN of the system interrupt status register (0x72, SYS_INTSTS) is set to 1. The user needs to write 1 to clear.

When the voltage/current zero-crossing interrupt output is enabled, USIGN/ISIGN of the system interrupt enable register (0x73, SYS_INTEN) is set to 1. To configure the voltage/current zero-crossing interrupt output by configuring IO Configuration Register 0 (0x7D, SYS_IOCFG0) or IO Configuration Register 1 (0x7E, SYS_IOCFG1). The output level of pin Px is automatically inverted according to the voltage zero-crossing flag USIGN/current zero-crossing flag ISIGN.

To configure the voltage/current zero-crossing interrupt output square wave by configuring IO Configuration Register 0 (0x7D, SYS_IOCFG0) or IO Configuration Register 1 (0x7E, SYS_IOCFG1). The output level of pin Px is automatically inverted according to the voltage/current zero-crossing status in real time. Each time a zero-crossing event occurs, the IO port is inverted once.

Voltage/current zero crossing detection, supporting voltage/current threshold detection function to prevent misjudgment of zero crossing when invalid input occurs. By opening control register 6 (0x80, DSP_CTRL6) and writing the threshold to be detected into the register (voltage for 0x94, ZERO_TH, and current for 0x95, ZERO_TH_I), the system will automatically compare whether the instantaneous RMS of voltage/current exceeds the threshold. If it does not exceed the threshold, it will be determined as an invalid input, and the interrupt output and zero crossing output of voltage/current will be masked, Until the instantaneous RMS of voltage/current exceeds the threshold or the threshold detection function is turned off.

The following figure is configured to enable the zero-crossing interrupt output. When the zero-crossing detection mode is selected as the negative zero-crossing point, the USIGN/ISIGN flag bit, the zero-crossing interrupt output, and the zero-crossing output square wave waveform.

Figure37. output waveform for voltage/current zero-crossing

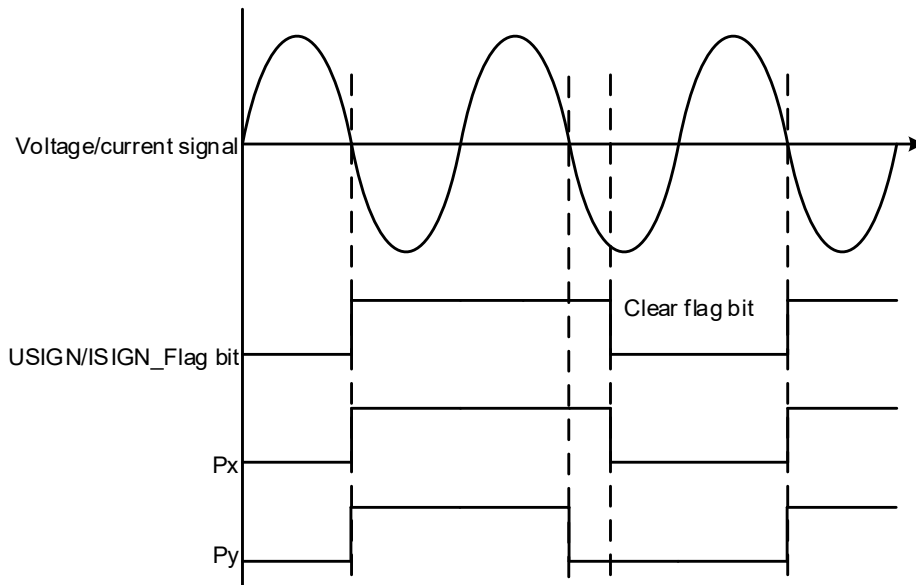

11.3 Voltage Swell/Dip

The V93XX can be programmed to indicate voltage swell/dip. See Voltage Swell or Dip Threshold Register.

When the voltage RMS value continuously exceeds the upper limit of the voltage surge threshold by N (units can be configured through the voltage surge register (0x8f, DIP_SWELL_CTRL)) for half a cycle is above the upper limit of the voltage swell threshold, the voltage swell status bit (USWELL of the SYS_STS system status register (0x74, SYS_STS)) is set to 1. At the same time, the voltage swell flag (USWELL of the system interrupt status register (0x72, SYS_INTSTS)) is set to 1, and the flag bit is written to 1 to clear.

When the voltage RMS value continuously exceeds the upper limit of the voltage surge threshold by N (units can be configured through the voltage surge register (0x8f, DIP_SWELL_CTRL)) for half a cycle is lower than the lower limit of the voltage swell threshold, the voltage swell status bit (USWELL of the SYS_STS system status register description (0x74, SYS_STS)) is restored to 0. At the same time, the end of voltage surge status bit (0x99, Bit [31] of DIP_SWEL_CTRL) is set to 1, and this flag bit is written as 1 clear 0.

When the voltage RMS value continuously exceeds the upper limit of the voltage surge threshold by N (units can be configured through the voltage surge register (0x8f, DIP_SWELL_CTRL)) for half a cycle is lower than the lower limit of the voltage dip threshold, the voltage dip status bit (UDIP of the SYS_STS system status register (0x74, SYS_STS)) is set to 1. At the same time, the voltage dip flag (UDIP of the system interrupt status register (0x72, SYS_INTSTS)) is set to 1, and the flag bit is written to 1 to clear.

When the voltage RMS value continuously exceeds the upper limit of the voltage surge threshold by N (units can be configured through the voltage surge register (0x8f, DIP_SWELL_CTRL)) for half a cycle is higher than the high limit of the voltage dip threshold, the voltage dip status bit (UDIP of the SYS_STS system status register description (0x74, SYS_STS)) is restored to 0. At the same time, the end status bit of voltage surge (0x99, Bit [30] of DIP_SWELL_CTRL) is set to 1, and this flag bit is written as 1 clear 0.

By reading register DAT_SWELL_CNT/DAT_DIP_CNT obtains voltage surge/drop time records and reads SWELL_REG_MAX_CNT/DIP_REG_MIN_CNT can obtain time records of voltage surges reaching maximum value /dips reaching minimum value. 24Bit is valid. Writing any value to this register can reset the count value.

By reading register SWELL_REG_MAX/DIP_REG_MIN can obtain records of the maximum/minimum values during voltage surges/dips.

The voltage swell interrupt flag and voltage dip interrupt flag can be configured by configuring the IO port output. See IO Configuration Register 0 (0x7D, SYS_IOCFCGX0) and IO Configuration Register 1 (0x7E, SYS_IOCFCGX1).

11.4 Over-voltage and under-voltage/Over-current and under-current

Figure38. Over-voltage and under-voltage/Over-current and under-current detect

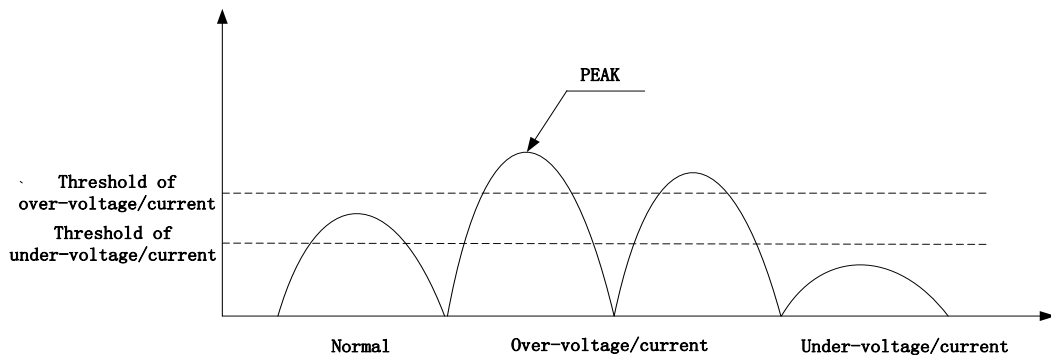

The V93XX can be programmed to indicate over-voltage/under-voltage of channel U, over-voltage/under-voltage of channel IA, and over-voltage/under-voltage of channel IB. See Fast detection Threshold Register. The user can enable the detection for over-voltage/under-voltage of channel U, over-current/under-current of channel IA, and over-current/under-current of channel IB by FDUEN, FDIAEN, and FFIBEN of metering control register 4 (Metering Control Register 4 (0x06, DSP_CTRL4)). The detection source supports high-pass filters and by-pass. The over-voltage or under-voltage/over-current or under-current detection time length is selectable.

1. Support waveform monitoring of three ADCs.
2. Each ADC waveform monitor has two thresholds: upper threshold (over-voltage, over-current); lower threshold (under-voltage, under-current)

3. Exceeding the upper limit threshold sample points: For example, if the set value is 4, it means that if more than 4 of the half cycle sampling points exceed the upper limit threshold, the half cycle waveform is considered to exceed the upper limit.
4. Exceeding the upper threshold half-cycle number: For example, if the set value is 2, it means that if two consecutive half-cycles are exceeding the upper limit, an over-voltage or over-current event is considered to occur.
5. Below the lower limit threshold sample points: For example, if the set value is 4, it means that if low than or equal to 4 of the half cycle sampling points exceed the low limit threshold, the half cycle waveform is considered to below the lower limit.
6. below the lower threshold half-cycle number: For example, if the set value is 2, it means that if two consecutive half-cycles are below the lower limit, an over-voltage or over-current event is considered to occur.
7. When the event occurs, the flag bit is generated. The user can check the system status bit (SYS_STS system status register (0x74, SYS_STS)) and the flag bit (system interrupt status register (0x72, SYS_INTSTS)).
8. The corresponding event flag can be configured by interrupt enable and IO port output.
9. Response time: When the half-wave number is set to 1 and enabled or disabled the high-pass filter, the response time is 10 ms, that is, when the input signal exceeds the threshold, the event interrupt can be output after a half cycle.

12 Energy Accumulator

Figure39. Functional block diagram of energy bucket

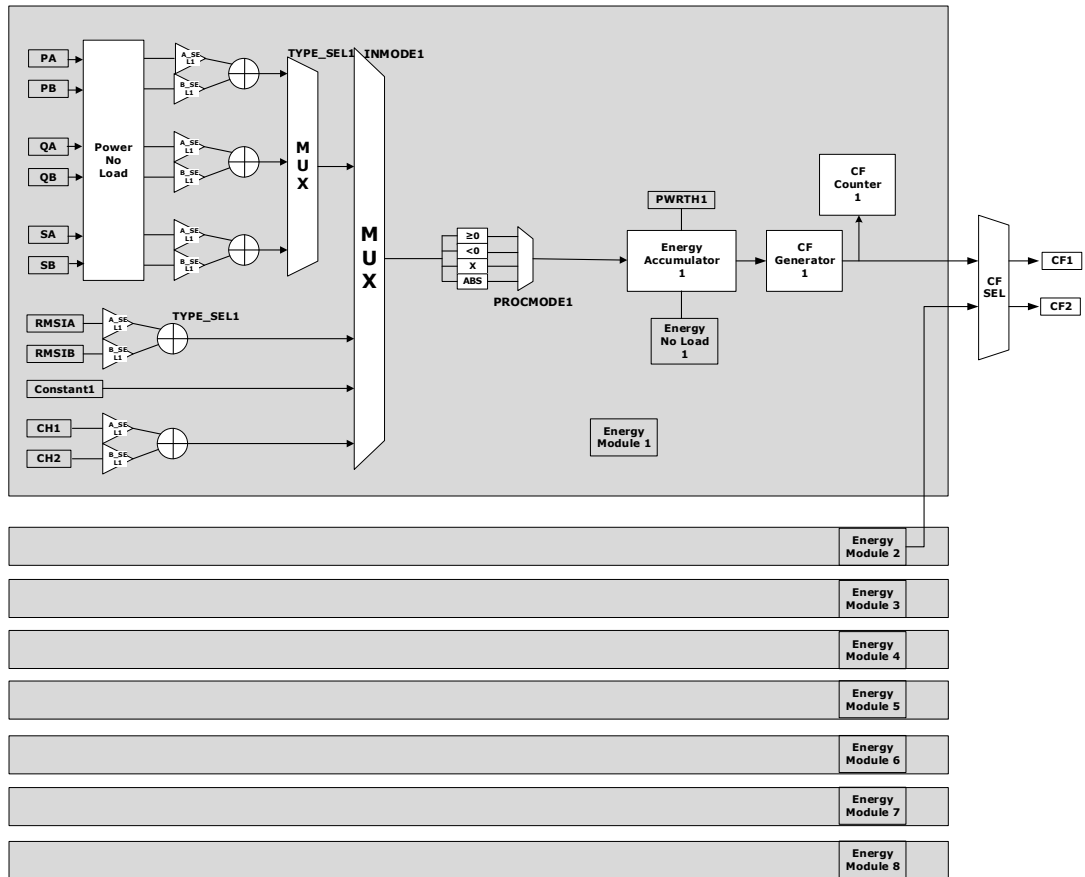

The V93XX has eight energy accumulators, including two high-speed energy accumulators and six low-speed energy accumulators. Each energy accumulators have four accumulation modes: power accumulation, current RMS accumulation, constant accumulation, and configurable fundamental channel accumulation.

The power accumulation is enabled by the channel an accumulation (A_SEL) and the channel B accumulation (B_SEL), which can realize only accumulating channel A power, only accumulating channel B power, and accumulating A and B power. Power can be selected for active power, reactive power and apparent power by TYPE_SEL.

The current accumulation is enabled by the channel An accumulation (A_SEL) and the channel B accumulation (B_SEL), which can realize only accumulating channel IA RMS, only accumulating channel IB RMS, and accumulating two-channel IA and IB RMS value can be selected by TYPE_SEL to accumulate the summation or accumulation difference of two channels (RMSIA+RMSIB or RMSIA-RMSIB).

The constant accumulation is not affected by enabling the A/B channel accumulation.

The power accumulation is enabled by the channel an accumulation (A_SEL) and the channel B accumulation (B_SEL), which can realize only accumulating channel A power, only accumulating channel B power, and accumulating A and B power. Power can be selected for active power, reactive power and apparent power by TYPE_SEL.

Configurable fundamental channel accumulation, enabled by A channel accumulation (A_SEL) and B channel accumulation switch, which can realize only accumulating fundamental channel 1 data, accumulating only fundamental channel 2 data, accumulating fundamental channel 1 plus accumulating fundamental channel 2.

There are four types of data operation that are accumulated for each input energy accumulator. Taking the active power of two channels as an example, the operation method is as follows.

0: The energy accumulator only accumulates positive numbers. Accumulate only positive data in PA and PB channels. When the data of a channel is negative, the data does not participate in accumulation.

1: The energy accumulator only accumulates negative numbers (in this case, the actual accumulated value is the positive number converted from the original value). Only negative data in the PA and PB channels is accumulated. When the data in the channel is positive, this data does not participate in the accumulation.

2: The energy accumulator accumulates the original value. Accumulate PA+PB.

3: The energy accumulator accumulates the absolute value. Accumulate $\text{abs}(PA) + \text{abs}(PB)$

12.1 High-speed Energy Accumulator

To enable high-speed energy accumulator 1, it needs to configure CALCEN1 (Bit[6]) in DSP_CTRL1 (Metering Control Register 2 (0x03, DSP_CTRL1)). To enable high-speed energy accumulator 2, it needs to configure CALCEN2 (Bit[7]) in DSP_CTRL1. The default accumulative acceleration of the high-speed energy accumulator is 204.8 KHz, and 32768 Hz can also be selected by the energy accumulator clock (bit23 in DSP_CTRL1), in the case of a low-speed clock, only constant accumulation mode can be used, and other modes are not supported.

High-speed energy accumulator supports CF output.

12.2 Low-speed Energy Accumulator

The six low-speed energy accumulators are enabled by DGY_LC_EN (Bit[15]) in DSP_CTRL1 (Metering Control Register 2 (0x03, DSP_CTRL1)). The default accumulated acceleration is 50 Hz.

The accumulation speed of low-speed energy accumulator is controlled by CURDAT_RATE (Bit[31]) in DSP_CTRL0 (Metering Control Register 0 (0x02, DSP_CTRL0)) and LCF_ACC

(Bit[22]) in DSP_CTRL1.

When CURDAT_RATE=0:

LCF_ACC=0, the accumulation period of the energy accumulators 3, 4, 5, 6, 7, 8 is 20 ms;

LCF_ACC=1, the accumulation period of the energy accumulators 3, 4, and 5 is 10 ms, and the energy accumulators 6, 7, and 8 are not accumulated.

- When CURDAT_RATE=0:

LCF_ACC=0, the accumulation period of the energy accumulators 3, 4, 5, 6, 7, 8 is 20 ms;

LCF_ACC=1, the accumulation period of the energy accumulators 3, 4, and 5 is 10 ms, and the energy accumulators 6, 7, and 8 are not accumulated.

- When CURDAT_RATE=1:

LCF_ACC=0, the accumulation period of the energy accumulators 3, 4, 5, 6, 7, 8 is 40 ms;

LCF_ACC=1, the accumulation period of the energy accumulators 3, 4, and 5 is 20 ms, and the energy accumulators 6, 7, and 8 are not accumulated.

12.3 CF Output

V93XX supports 2 channels of CF. The CF output is configured by the Meter Control Register 1 (Metering Control Register 2 (0x03, DSP_CTRL1)) to select the IO port output.

CF supports source selection. It can be selected from the energy accumulator 1 or the energy accumulator 2.

CF supports polarity selection, pulse width selection, and accelerated weak-signal calibration.

Refer to the description of CF in Metering Control Register 1 (0x03, DSP_CTRL1) for details.

12.4 Energy Accumulator Power-creep Detection

Energy accumulator anti-creep threshold. When anti-creep energy accumulator exceeds the EGY_CRPTH and high-speed energy accumulator not exceeds the EGY_PWRTH, the accumulating value of high-speed accumulator will be cleared.

There is a power-creep energy accumulating register for energy accumulator 1 and 2, which they have the same accumulation speed.

User should configure threshold for the power-creep threshold register (EGY_CRPTH) and energy accumulating threshold register (EGY_PWRTH). If the accumulating value of power-creep energy accumulator register reaches the value of EGY_CRPTH first, the energy accumulating register will be cleared, and system enter the power-creep status. When the accumulating value of energy accumulating register reaches the value of EGY_PWRTH, the power-creep energy register will be cleared, system start to work and operating normally.

The actual bit width of register EGY_CRPTH is 32bit. The register contents will be padded with 0s automatically in the 4 least significant bits when the power-creep calculated. It would be calculated after extended to 36 digits.

User can judge whether in power-creep status through SYS_STS (BIT19, BIT18).

12.5 Active Accumulation uploading Interface

Active data uploading interface can configure pins, P0/ P1/ P2/ P3/ P4/ P5/ P6, to be the active data interface through SYS_IOCFGX.

1. Asynchronous transfer mode by 1 data wire.
2. Interface configuration: 11-bit transmission (start bit + 8 data bit + parity bit + stop bit)

Communication baud rate: SPI communication data rate is 4800, it also can operate at 9600.

UART communication data rate is same as present baud rate, also double the present baud rate.

To enable the function of double baud rate if BIT17 setting to 1 at the metering control register 1 (Metering Control Register 2 (0x03, DSP_CTRL1)).

3. Communication time interval: 20 ms/ 40 ms (the same to instantaneous power refresh time)
4. Frame header: 0x7D
5. Checksum: the energy accumulator 1 accumulating data plus the energy accumulator 2 accumulating data. Total accumulate 8 bytes and reverse them, then plus 0x33 to obtain the checksum.
6. Frame length: 10 bytes
7. To enable this block by BIT 16 of metering control register 1 (DSP_CTRL1).

Protocol format as below:

frame header	the energy accumulator 1 accumulating data	the energy accumulator 2 accumulating data	checksum
0x7D	4 bytes	4 bytes	1 byte

13 Signal IO Ports

13.1 Overview

The V93XX provides up to seven signal outputs, and seven output signals are used to map the internal output sources.

13.2 Functional Description

The seven signal output ports can be configured as CF output, energy upload interface, waveform active upload DMA channel interface, zero-crossing square wave and four types of interrupt output. The signal output port can be set to output a single signal, or it can be set to output certain types of interrupt signals. See IO Configuration Register 0 (0x7D, SYS_IOCFGX0) and IO Configuration Register 1 (0x7E, SYS_IOCFGX1) for details.

1st type interruption: current zero-crossing interruption, voltage zero-crossing interruption, high-speed energy accumulator 1/2 overflow interruption.

2nd type interruption: waveform refreshes interruption, instantaneous RMS refresh interruption, average RMS refreshes interruption, instantaneous power value refresh interruption, average power value refreshes interruption, waveform storage finish interruption, waveform storage overflow interruption and waveform data upload finished interruption.

3rd type interruption: IB channel under-current interruption, IB channel over-current interruption, IA channel under-current interruption, IA channel over-current interruption, voltage channel under-voltage interruption, voltage channel over-voltage interruption, voltage dip interruption and voltage swell interruption, the end of voltage drop interruption, the end of voltage rise interruption, RCH clock output, RCL clock output.

4th type interruption: SPI communicating error interruption, UART communicating error interruption, parameters self-checking error interruption, phase measurement finished interruption, power-down interruption, reference error interruption, CTI external input clock error interruption and RAM self-checking error interruption.

Figure40. Functional Block Diagram of signal IO ports

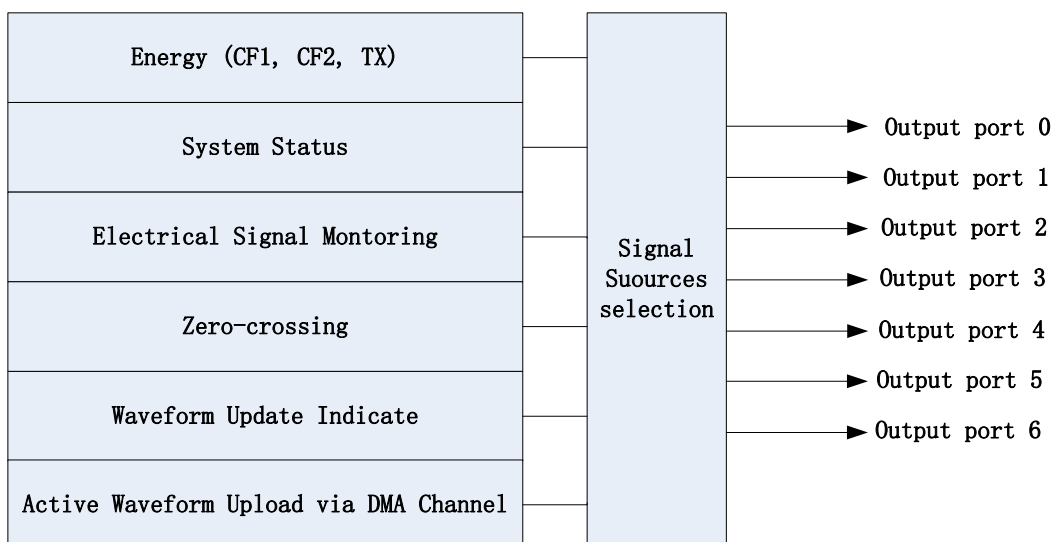

Description:

1. When the output port is used as the CF output, it is supported to set the width of the output pulse and select the output polarity. When the output period is less than twice the CF output pulse width, CF is output at a duty cycle of 50%. For example, if the output width is 80 ms and the output period is less than 160 ms, it will be output according to the duty cycle of 50%.
2. Using the UART protocol when the TX output for energy upload.
3. When used as the interrupt event output port, the output port defaults to low level output. If the event occurs, it outputs a high level until the user clears the event flag bit, and the output state returns to the default level.
4. When used as a zero-crossing square wave output, the output port defaults to a low-level output. If configured as a positive zero-crossing, the IO port flips when the signal transitions from a negative signal to a positive signal.
5. When used as a DMA output port, the SPI protocol is required, and the user is required to select the SPLK, SPDO, and SOCS ports.

14 Roche coil processing

When the external sampling circuit adopts the Roche coil method, it is necessary to integrate the input current signal in order to truly restore the sampled current signal,

The relationship between the induced voltage of the Roche coil and the measured current is as follows:

$$U_{\text{out}} = M \frac{di}{dt}$$

M indicates that the differential of current over time is proportional to the measured voltage. By adjusting the value of M (coil turns, type, etc.), U_{out} can be controlled within a reasonable range (1% -100% range of ADC) to obtain more accurate results. By integrating the output voltage again, the current to be measured can be obtained, At the same time, the voltage output by the Roche coil should have a 90° phase relationship with the voltage channel (the coil voltage output by the Roche coil lags behind the voltage channel by 90°).

When configure register DIDT_IA_ON (Bit [28]) in DSP_CTRL6 and DIDT_IB_ON (Bit [27]) is enable, the system will automatically perform the integration operation of ADC sampling data to obtain the true current value.

DIDT_IA_ON (Bit [28]) in DSP_CTRL6 and DIDT_IB_ON (Bit [27]) and Fundamental Precision Improvement Switch FUND_PREC_ON [24], limited by the number of instructions processed, cannot be opened simultaneously. If both are turned on, the default Roche coil is valid, but there will be errors in the fundamental wave measurement data.

15 Packaging Information

Figure41. Taping Information of V9340

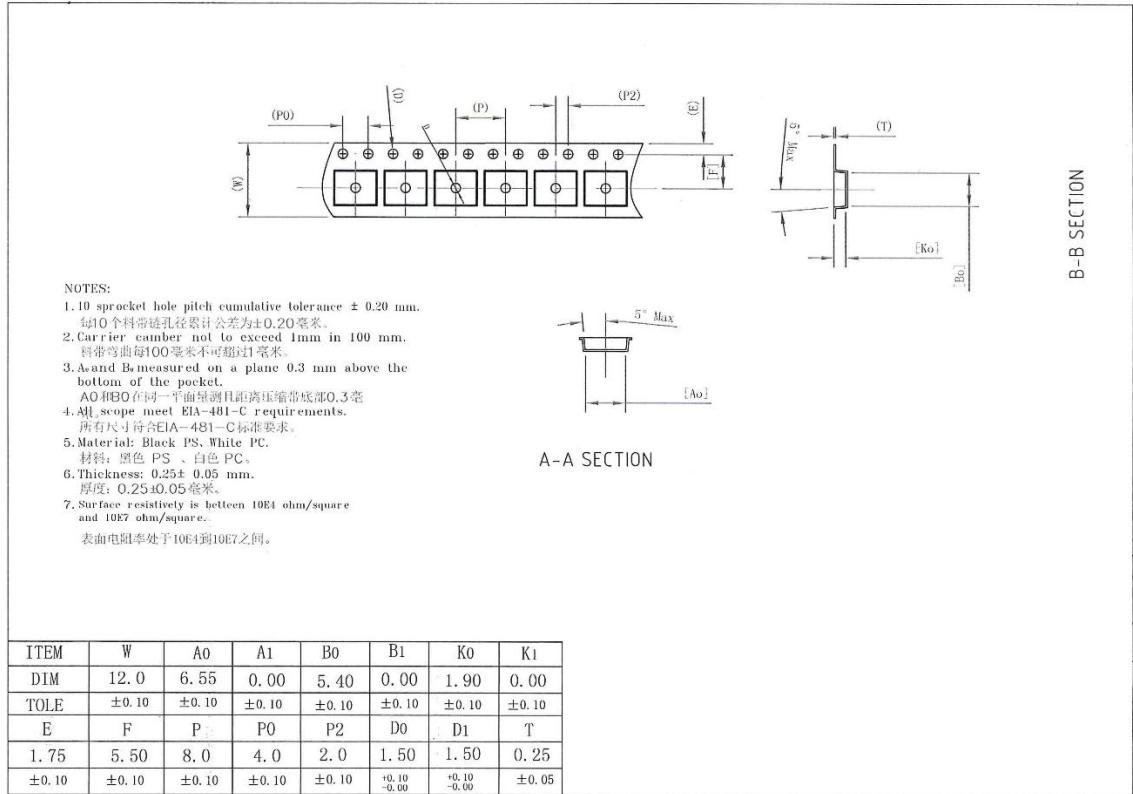

Figure42. Taping Information of V9360

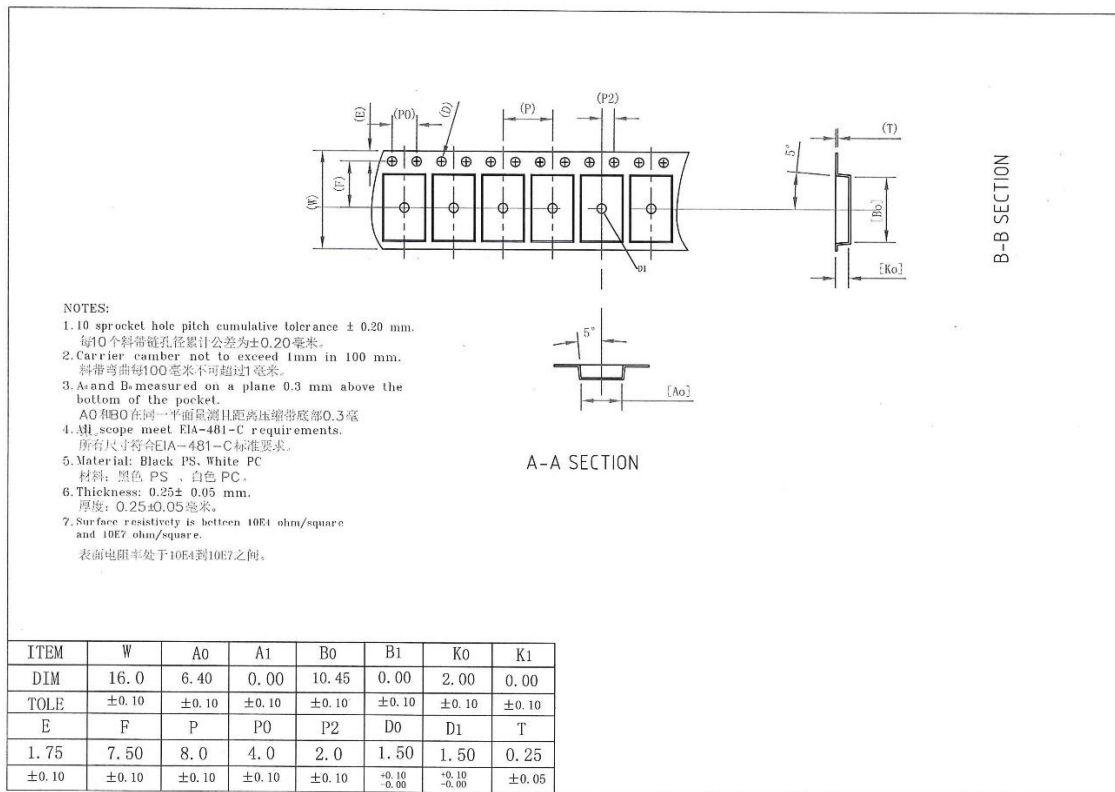
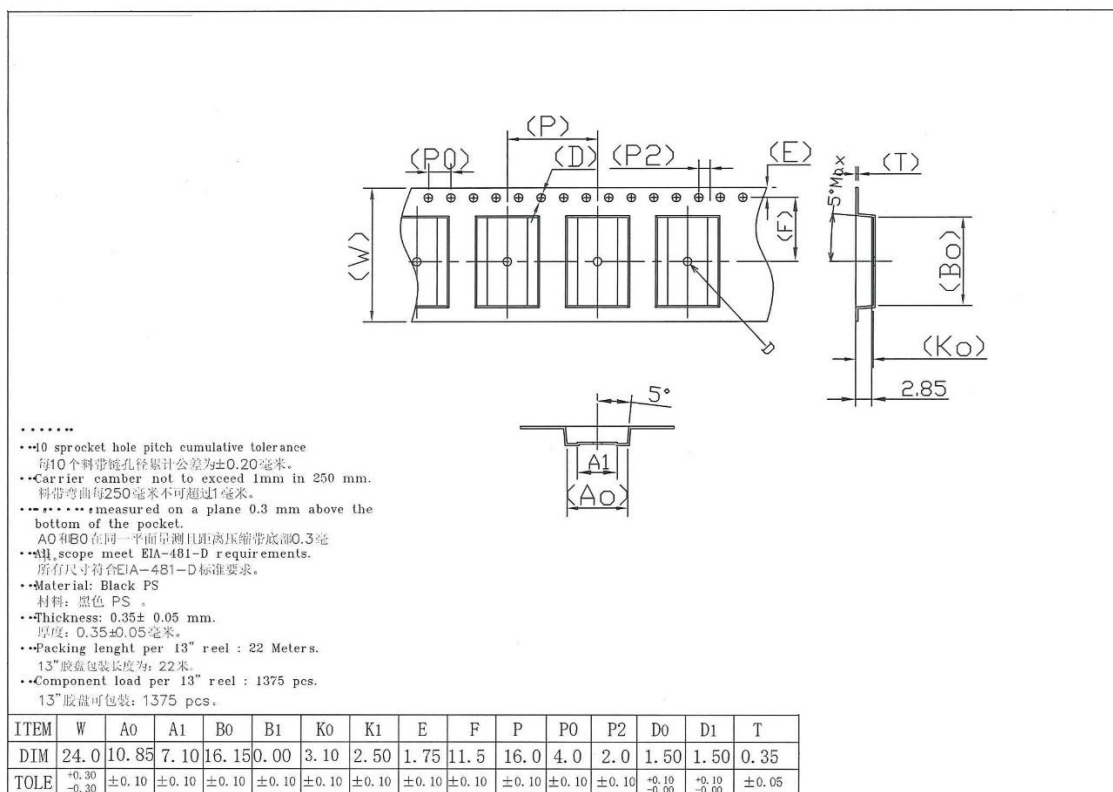

Figure43. Taping Information of V9381



16 Reflow soldering process

All Wango chips provided to customers are lead-free RoHS compliant products.

The reflow soldering process recommended in this article is a lead-free reflow soldering process, which is suitable for the pure lead-free process of lead-free solder paste. If customers need to use lead solder paste, please contact the smart chip FAE connect.

See Table83 for lead-free reflow profile conditions. This table is for reference only.

Table83. Reflow profile conditions

QTI typical SMT reflow profile conditions(for reference only)		
	Step	Reflow condition
Environment	N2 purge reflow usage (yes/no)	Yes, N2 purge used
	If yes, O2 ppm level	O2 < 1500 ppm
A	Preheat ramp up temperature range	25°C -> 150°C
B	Preheat ramp up rate	1.5~2.5 °C /sec
C	Soak temperature range	150°C -> 190°C
D	Soak time	80~110 sec
E	Liquidus temperature	217°C
F	Time above liquidus	60-90 sec
G	Peak temperature	240-250°C
H	Cool down temperature rate	≤4°C /sec

The figure below shows a typical lead-free reflow mode.

Figure44. A typical lead-free reflow mode

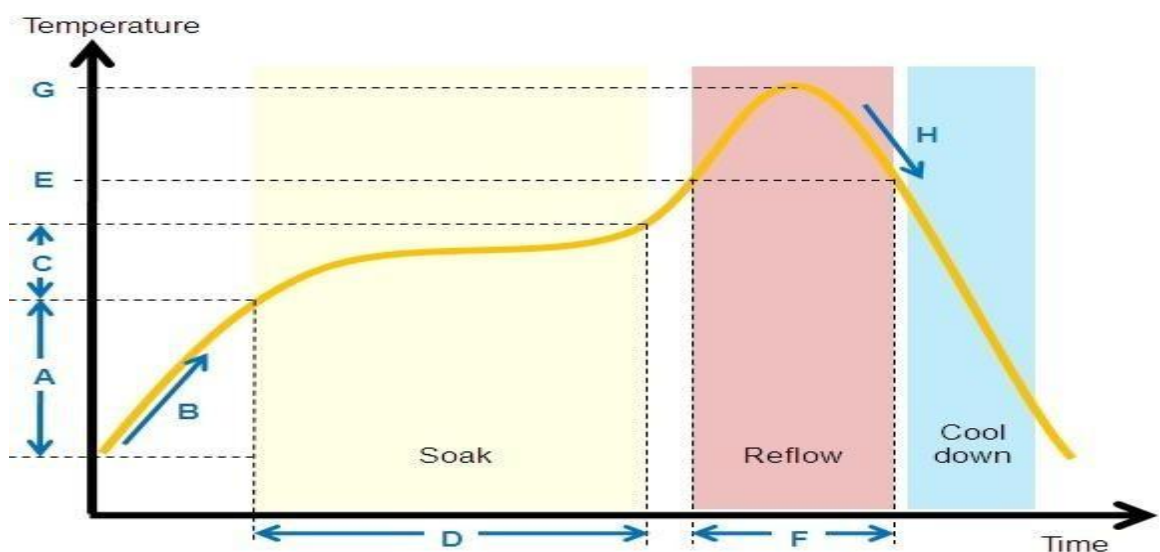

17 Outline Dimensions

Figure45. Outline dimension for V9381

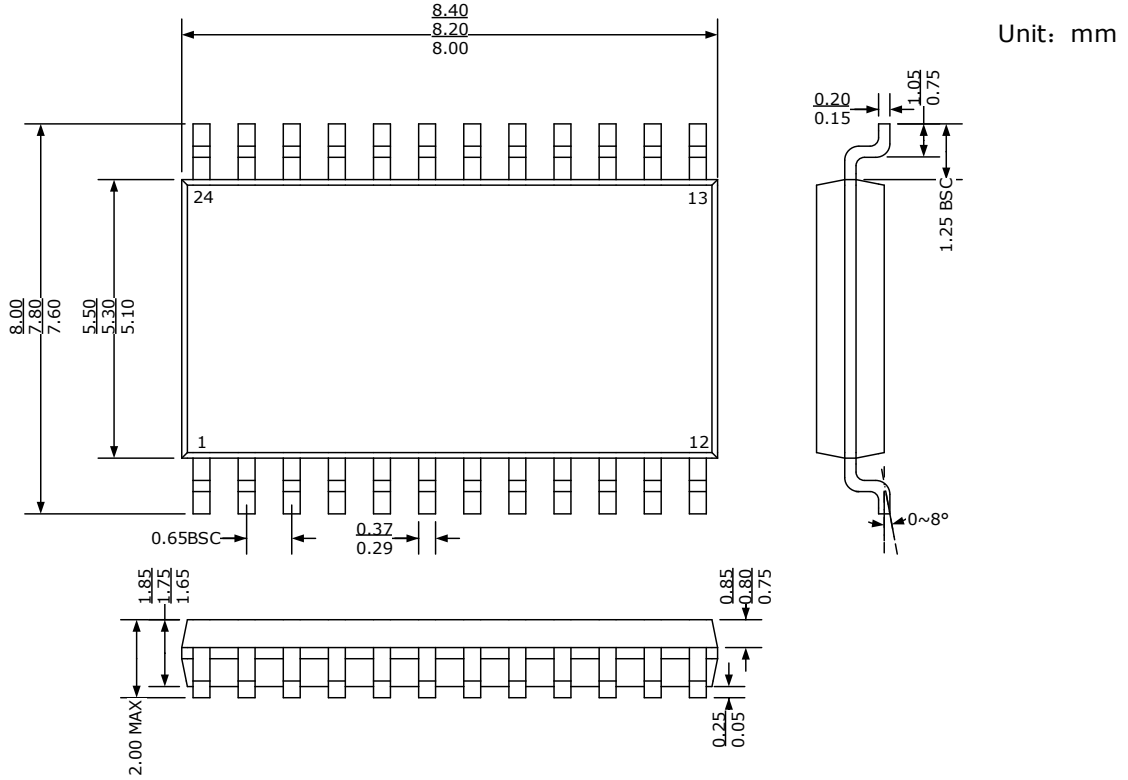

Figure46. Outline dimension for V9360

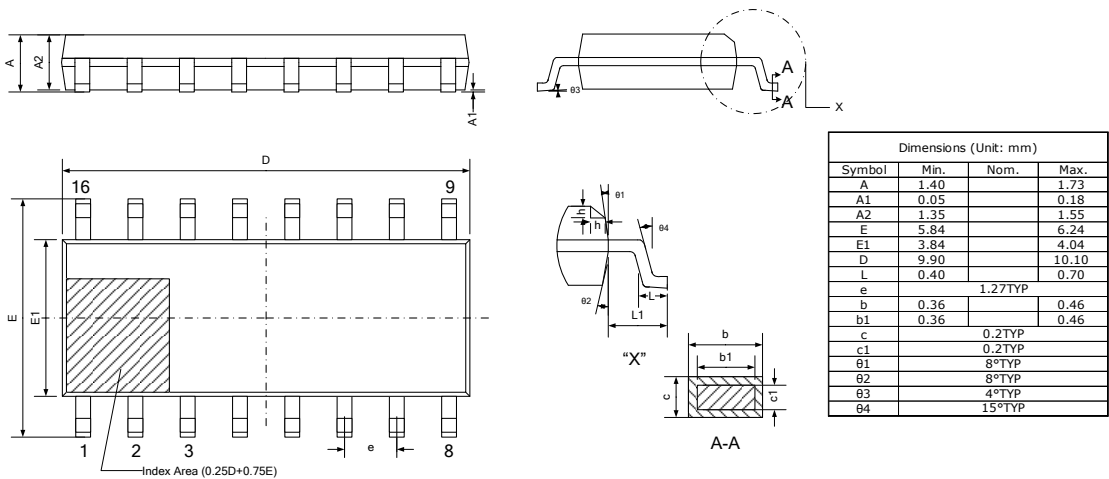
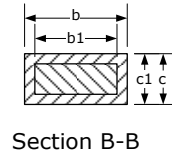
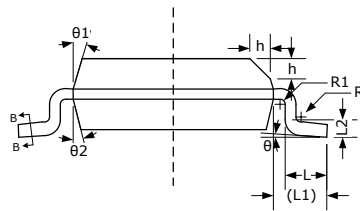
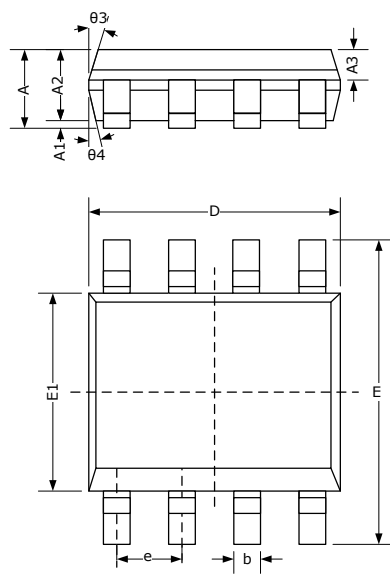

Figure47. Outline dimension for V9340



Dimensions (Unit: mm)

Symbol	MIN	NOM	MAX
A	1.35	1.55	1.75
A1	0.05	0.15	0.25
A2	1.25	1.40	1.65
A3	0.50	0.60	0.70
b	0.38	-	0.51
b1	0.37	0.42	0.47
c	0.17	-	0.25
c1	0.17	0.20	0.23
D	4.80	4.90	5.00
E	5.80	6.00	6.20
E1	3.80	3.90	4.00
e	1.27BSC		
L	0.45	0.60	0.80
L1	1.04REF		
L2	0.25BSC		
R	0.07	-	-
R1	0.07	-	-
h	0.30	0.40	0.50
theta	0°	-	8°
theta1	15°	17°	19°
theta2	11°	13°	15°
theta3	15°	17°	19°
theta4	11°	13°	15°

Innovates for the Internet of Energy

VANGO TECHNOLOGIES, INC.

Add:368 Liuhe Rd, North Bldg, Hi-Tech Park, Binjiang, Hangzhou, China

Tel:+86-571-88157065

Fax:+86-571-88157067

Email:service@vangotech.com

<https://www.vangotech.com/en>